

## FEATURES

### 0.4mm (.0157inch) Pitch

- <-1db insertion loss to 24.1GHz
- <2:1VSWR to 27.1GHz
- $Z_0 = 45.4 \Omega$
- <30ps risetime thru  $50 \Omega$
- 60 milliOhms contact resistance
- 2.0 Amps max. drive current

### 0.5mm (.0197inch) Pitch

- <-1db insertion loss to 33.3 GHz
- <2:1VSWR to 37.1 GHz
- $Z_0 = 53.9 \Omega$
- <30ps risetime thru  $50 \Omega$
- 60 milliOhms contact resistance
- 2.0 Amps max. drive current

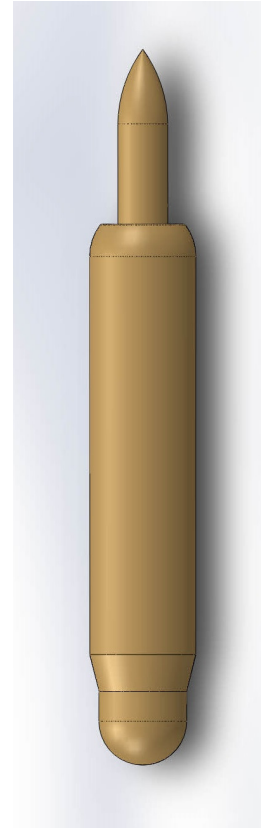

## GENERAL DESCRIPTION

The A1520 spring probes from Signal Integrity Inc. are designed to meet the rigorous test requirements driven by the ultra fast risetimes in the digital domain, and high bandwidth, high frequency RF / microwave specifications for the wireless market. Along with speed and accuracy, these probes are designed to operate at pitches to 0.4mm, specifically for the ultra fine pitch packaging these markets demand.

The ultra high bandwidth of these probes provides very low insertion loss up to 24.1GHz. These probes will provide transparent operation on Bluetooth, 802.11b and 3G wireless protocol devices as well as exceed the test probe demands of proprietary microwave communications devices and systems.

With an impulse risetime of less than 30ps and a propagation delay of 9ps, the A1520 has more than enough performance for probe applications and interconnection solutions in broadband digital. These probes are ideal for building transparent test channels or interconnection solutions that must address data communication and source synchronous memory busses. Among others, these include Infiniband, PCI-Express, Source Synchronous DDR, Rambus<sup>™</sup>, HyperTransport and 10Gb Ethernet.

**SERIES A1520 MODELS: ORDERING INFORMATION**

A Series 0.4mm (.0157inch) Pitch				
Model	Length Operating / Initial inches [mm]	DUT Plunger and Plating	Spring	Operating Spring Force
A1520-A1	.075 [1.90] / .081 [ 2.05]	Sharp point - Gold	Music wire	20 Grams
A1520-B2		4 Point Crown - Gold		
A1520-V4		4 Point Crown - Gold	Stainless Steel	21 Grams
A1520-W5		Sharp point - Gold		

**FUNCTIONAL SPECIFICATIONS**

Model	A1520-B2 0.4mm pitch			A1520-B2 0.5mm pitch			
Time Domain	Min.	Typ.	Max.	Min.	Typ.	Max.	Units
TDT Risetime into 50Ω			30.0			30.0	ps
TDR Risetime open circuit			30.0			28.5	ps
TDR Risetime short circuit			27.0			25.5	ps
Signal Delay into 50Ω		9.0			9.0		ps
<b>Frequency Domain</b>							
Insertion Loss <-1db	24.1			33.3			GHz
<-3db	>40.0			>40.0			GHz
Return Loss, S11 <-10db	26.0			36.0			GHz
<-20db	13.0			26.0			GHz
VSWR <2:1	27.1			37.1			GHz
<b>Equivalent Circuit Parameters</b>							
Pin Inductance		0.44			0.55		nH
Pin Capacitance to ground, C1, C2		0.23			0.18		pF
Mutual Inductance		0.11			0.11		nH
Mutual Capacitance		0.04			0.03		pF
Transmission Line Zo		45.4			53.9		Ω
Tl		9			9		ps
<b>DC Parameters</b>							
Contact Resistance	60						mΩ
<b>Maximum Rating</b>							
Drive Current	2						A

0.4mm (.0157inch) Pitch

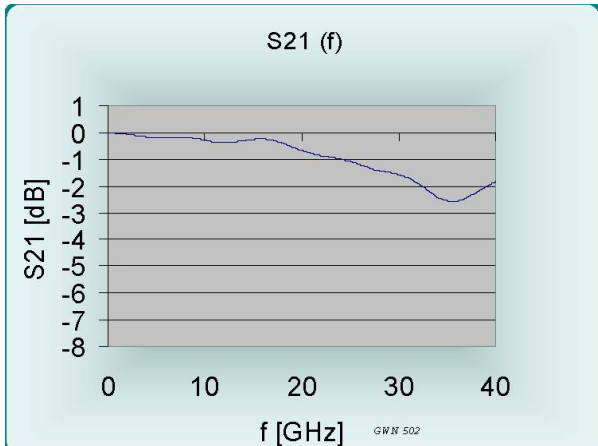

Figure 1: Insertion Loss, S21, A1520-B2

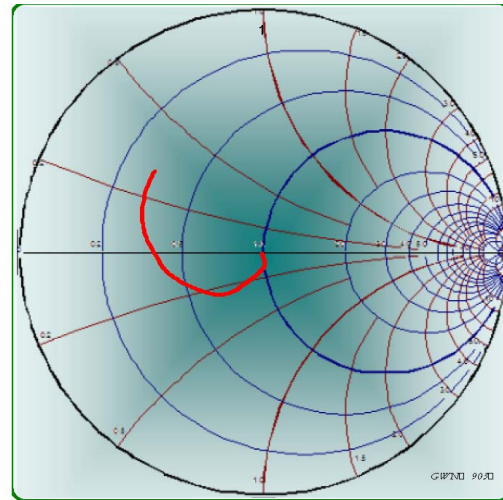

Figure 2: Measurement into 50Ω, A1520-B2

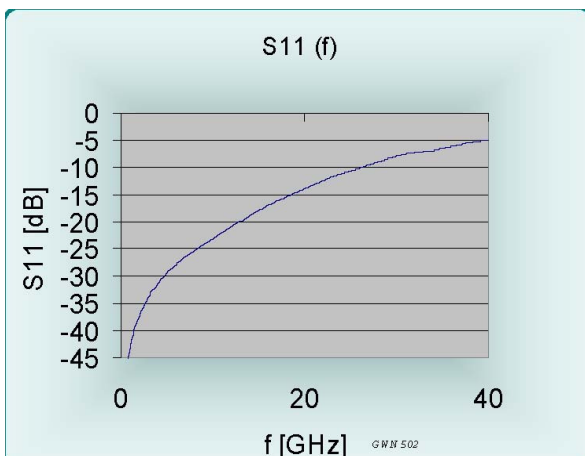

Figure 3: Return Loss, S11, A1520-B2

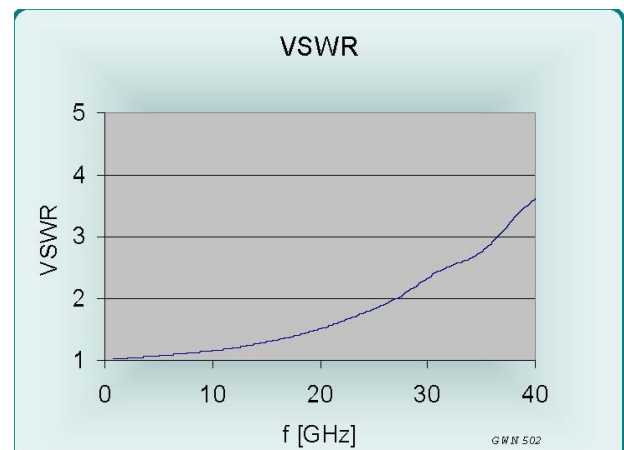

Figure 4: VSWR, A1520-B2

**0.4mm (.0157inch) Pitch**  
**EQUIVALENT CIRCUITS / SPICE MODELS**

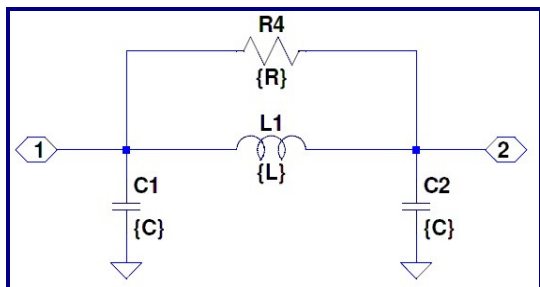

Figure 5 Pi Equivalent, Valid to <23GHz

C1, C2	0.12	pF
L1	0.44	nH
R4	2000	Ohms

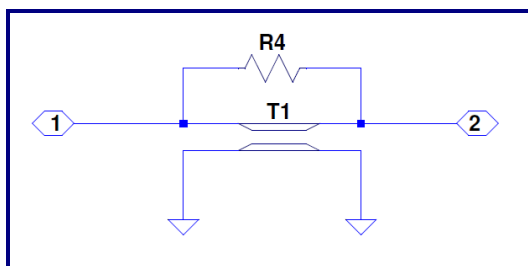

Figure 6 Transmission Line Model,  
 Valid to >40GHz

Z0	45.4	Ohms
L	9	ps
R4	2000	Ohms

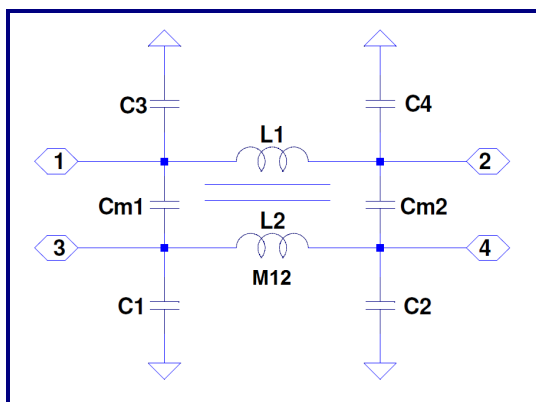

Figure 7: Lumped, Mutual Elements

C1,2,3,4	0.116	pF
Cm1, Cm2	0.021	pF
L1, L2	0.44	nH
M12	0.108	nH

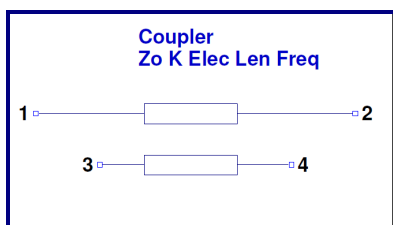

Figure 8: Transmission Line  
 Equivalent for Crosstalk

Z0	45.4	Ohms
Lel	9	ps
k	0.25	
f	55.6	GHz

0.5mm (.0197inch) Pitch

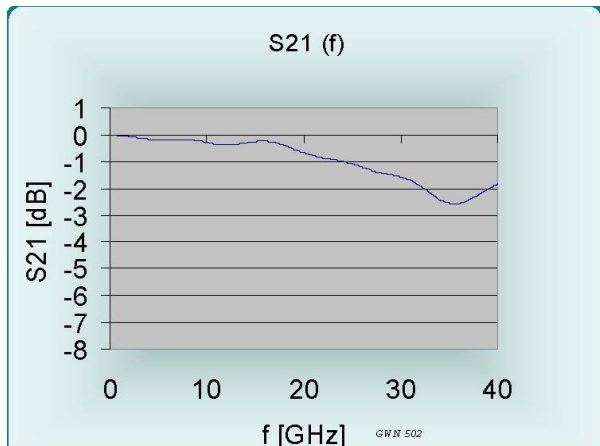

Figure 9: Insertion Loss, S21, A1520-B2

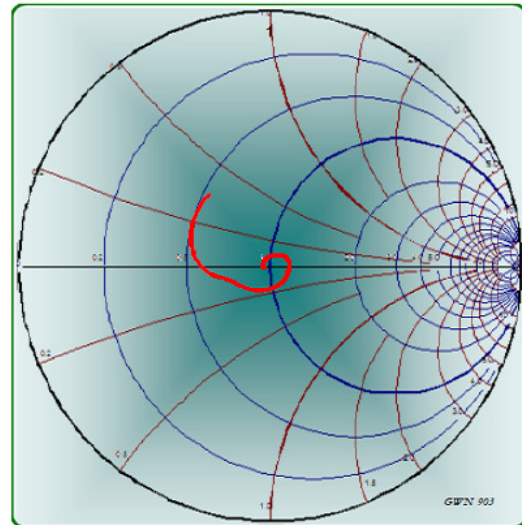

Figure 10: Measurement into 50Ω, A1520-B2

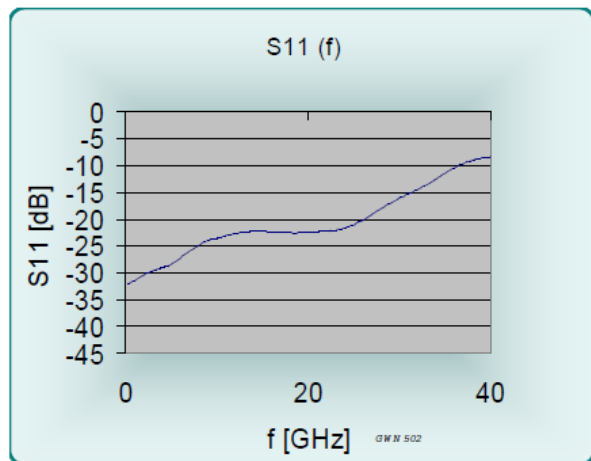

Figure 11: Return Loss, S11, A1520-B2

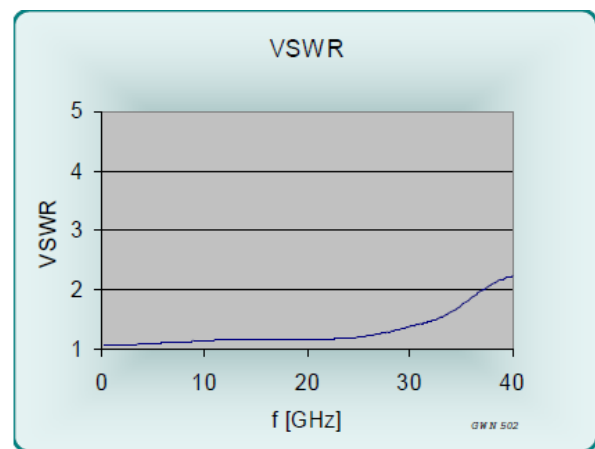

Figure 12: VSWR, A1520-B2

**0.5mm (.0197inch) Pitch**  
**EQUIVALENT CIRCUITS / SPICE MODELS**

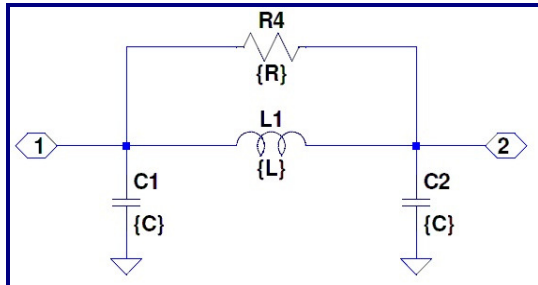

Figure 13: Lumped, Valid to <24GHz GSG Configuration

$C_g = C1+C2$	L1	R4
0.18 pF	0.55 nH	1000 $\Omega$

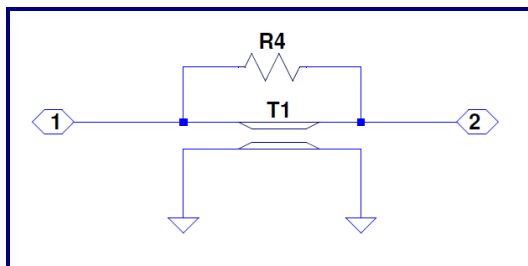

Figure 14: Transmission Line

Zo	L	R4
53.9 $\Omega$	9 ps	1000 $\Omega$

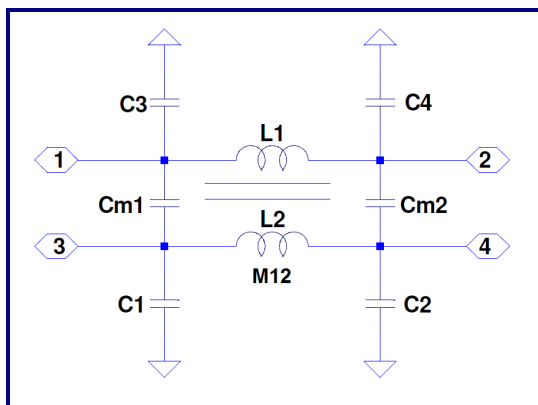

Figure 15: Lumped, Mutual Elements GSSG Configuration

C1,2,3,4	Cm1,Cm2	L1,L2	M
0.088	0.014 pF	0.55	0.110 nH

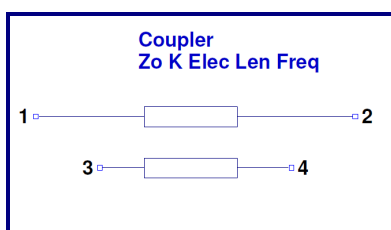
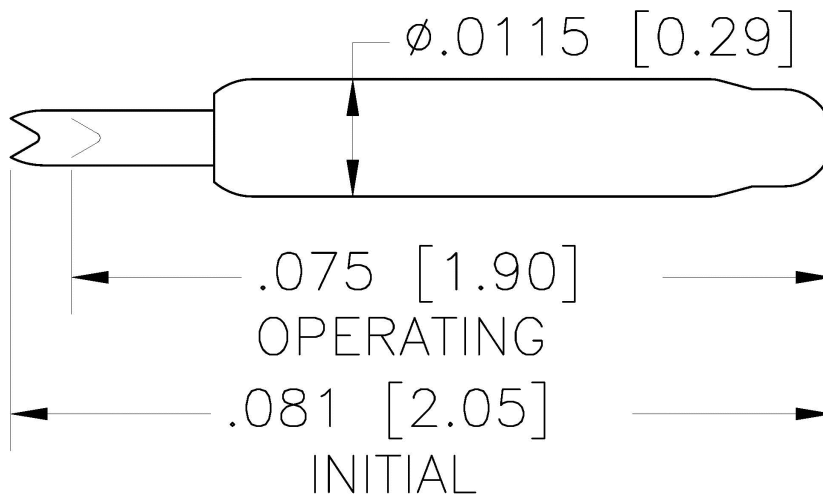

Figure 16: Transmission Line for Crosstalk

Z0	53.9	Ohms
k	0.20	
f	55.6	Ghz

**A SERIES MODELS**
**A Series 0.4mm (.0157) pitch**

Probe Series	Initial Length inch/mm		Operating Position inch/mm		Operating Spring Force	Self Inductance	Insertion Loss < -1db to	Typical Contact Resistance	Maximum Current
<a href="#">A1512</a>	.131"	3.32	.119"	3.02	18-29g	0.66 nH	20.3 GHz	72 mOhms	2.0 A
<a href="#">A1520</a>	.081"	2.05	.075"	1.90	20g	0.44 nH	24.1 GHz	60 mOhms	2.0 A
<a href="#">A1540</a>	.126"	3.20	.114"	2.90	22-29g	0.42 nH	16.1 GHz	20 mOhms	4.3 A
<a href="#">A1550</a>	.133"	3.30	.118"	3.00	20-29g	0.71 nH	18.7 GHz	85 mOhms	2.0 A
<a href="#">A1561</a>	.149"	3.78	.131"	3.33	16-29g	0.67 nH	7.4 GHz	90 mOhms	1.65 A
<a href="#">A1562</a>	.160"	4.06	.144"	3.66	14-30g	0.80 nH	11.6 GHz	90 mOhms	1.45 A
<a href="#">A1580</a>	.210"	5.33	.192"	4.88	16-32g	1.02 nH	7.4 GHz	95 mOhms	1.55 A
<a href="#">A1582</a>	.210"	5.33	.184"	4.67	16-30g	0.93 nH	9.6 GHz	100 mOhms	1.4 A
<a href="#">A1586</a>	.219"	5.56	.199"	5.06	19-20g	-	-	-	-

**MECHANICAL DIMENSIONS**  
 INCHES [MM]

**Signal Integrity, Inc.**

104 County Street, Ste. 210, Attleboro, MA 02703 USA

 Tel: 1-508-226-6480 Fax: 1-508-226-6488 Internet: [www.signalin.com](http://www.signalin.com)

Signal Integrity makes no representation that the use of its products described herein, or the use of other technical information contained herein, will not infringe on existing or future patent rights. The descriptions contained herein do not imply the granting of licenses to make, use, or sell equipment constructed in accordance therewith. Specifications are subject to change without notice.