

**FEATURES**

- <-1db insertion loss to 18.7 GHz
- <2:1VSWR to 17.7GHz
- 20g operating spring force
- $Z_0 = 41.1\Omega$
- <31.5ps risetime
- 85 milliOhms contact resistance
- 2 Amps max. drive current

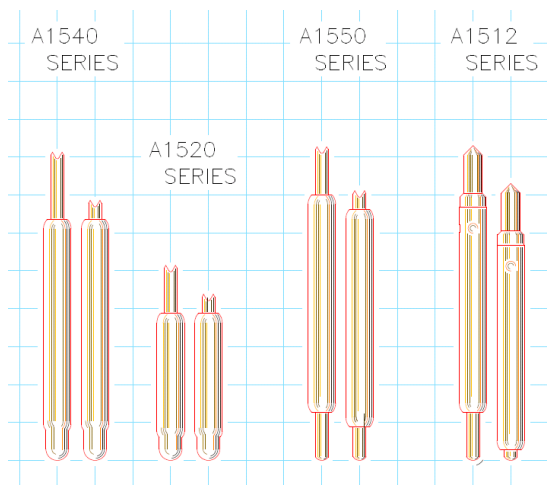

**GENERAL DESCRIPTION**

The A1550 spring probe from Signal Integrity Inc. is designed to meet the rigorous test requirements driven by the ultra fast risetimes in the digital domain, and high bandwidth, high frequency RF / microwave specifications for the wireless market. Along with speed and accuracy, these probes are designed to operate at pitches to 0.4mm, specifically for the ultra fine pitch packaging these markets demand.

The ultra high bandwidth of these probes provides very low insertion loss up to 18.7GHz. These probes will provide transparent operation on Bluetooth, 802.11b and 3G wireless protocol devices as well as exceed the test probe demands of proprietary microwave communications devices and systems.

With an impulse risetime of less than 31.5ps and a propagation delay of 16.5ps, the A1550 has more than enough performance for probe applications and interconnection solutions in broadband digital. These probes are ideal for building transparent test channels or interconnection solutions that must address datacom and source synchronous memory busses. Among others, these include Infiniband, PCI-Express, Source Synchronous DDR, Rambus<sup>™</sup>, HyperTransport and 10Gb Ethernet.

**SERIES A1550 MODELS: ORDERING INFORMATION**

A Series 0.4mm (.0157) Pitch					
Model	Length Operating / Initial inches [mm]	DUT Plunger and Plating	Interface Plunger	Spring	Operating Spring Force
A1550-D4	.118" [3.00] / .130" [3.30]	4 Point Crown - Gold	Spherical	Music wire	20 Grams
A1550-E5		4 Point Crown - Pd	Spherical		
A1550-F6		Ogive - Palladium	Spherical		
A1550-G7		Ogive - Gold	Spherical		
A1550-J9	.128" [3.25] / .140" [3.56]	4 Point Crown - Gold	Spherical		

**FUNCTIONAL SPECIFICATIONS**

Model	A1550-D4			
Time Domain	Min.	Typ.	Max.	Units
TDT Risettime into 50Ω			31.5	ps
TDR Risettime open circuit			33.0	ps
TDR Risettime short circuit			33.0	ps
Signal Delay into 50Ω		16.5		ps
Frequency Domain				
Insertion Loss <-1db	18.7			GHz
<-3db	27.1			GHz
Return Loss, S11 <-10db	17.1			GHz
<-20db	8.2			GHz
VSWR <2:1	17.7			GHz
Equivalent Circuit Parameters				
Pin Inductance		0.71		nH
Pin Capacitance to ground, C1, C2		0.197		pF
Mutual Inductance		0.102		nH
Mutual Capacitance		0.056		pF
Transmission Line Zo		41.1		Ω
Tl		16.5		ps
DC Parameters				
Contact Resistance		85		mΩ
Maximum Rating				
Drive Current		2.0		A

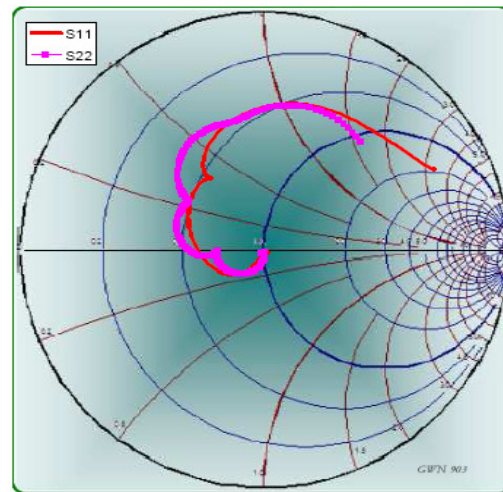

Figure 2: Measurement into 50Ω, A1550-D4

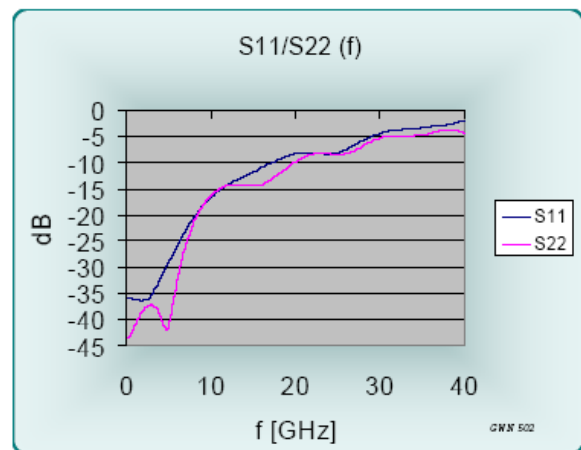

Figure 3: Return Loss, S11, A1550-D4

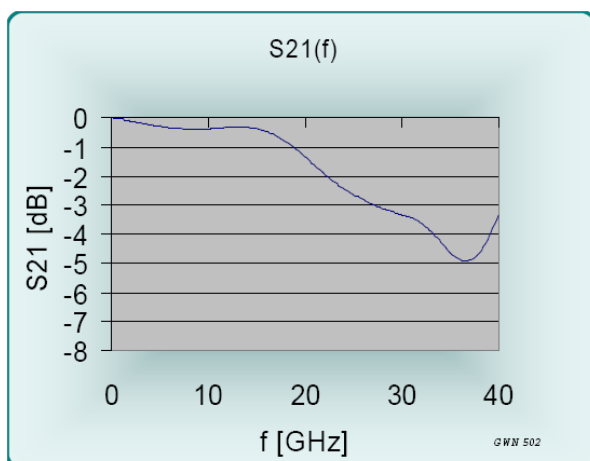

Figure 1: Insertion Loss, S21, A1550-D4

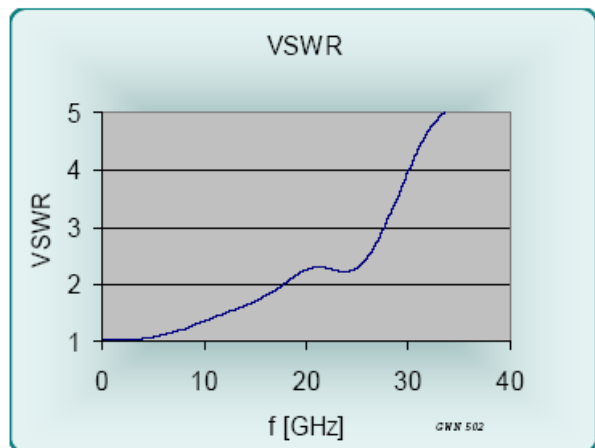

Figure 4: VSWR, A1550-D4

EQUIVALENT CIRCUITS / SPICE MODELS

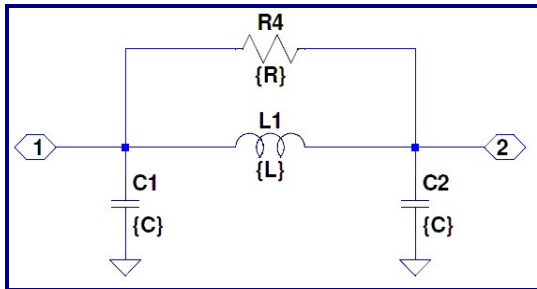

Figure 5: Lumped, Valid to 14GHz

Site	Cg = C1+C2	L1	R4
Corner	0.301 pF	1.01 nH	1000 Ω
Edge	0.358 pF	0.80 nH	1000 Ω
Field	0.393 pF	0.71 nH	1000 Ω
Diagonal	0.393 pF	0.71 nH	1000 Ω

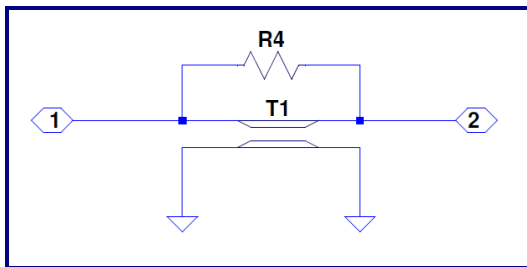

Figure 6: Transmission Line Model Valid to >40GHz

	Zo	L	R4
Corner	57.8 Ω	17.39 ps	1000 Ω
Edge	47.1 Ω	16.88 ps	1000 Ω
Field	42.4 Ω	16.64 ps	1000 Ω

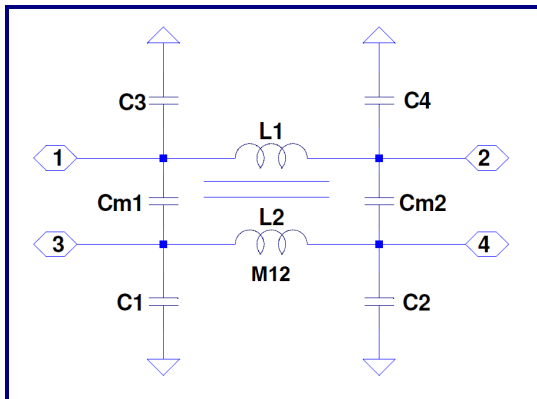

Figure 7: Lumped, Mutual Elements

Site	C1,2,3,4	Cm1,Cm2	L1,L2	M
Corner	0.150	0.052 pF	1.01	0.265 nH
Edge	0.179	0.046 pF	0.80	0.201 nH
Field	0.196	0.028 pF	0.71	0.102 nH
Diagonal	0.196	0.008 pF	0.71	0.032 nH

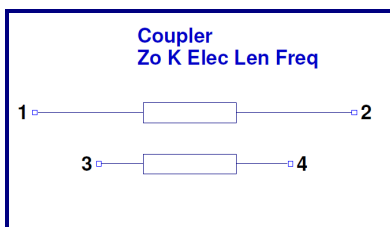
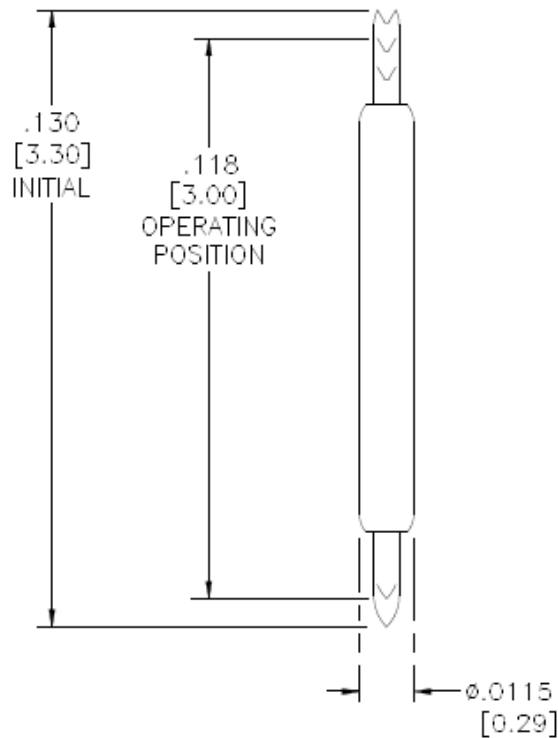

Figure 8: Transmission Line Equivalent for Crosstalk

Z0	41.4	Ohms
Lel	16.5	ps
k	0.15	
f	30.3	Ghz

**A Series 0.4mm (.0157) pitch**

Probe Series	Initial Length inch/mm		Operating Position inch/mm		Operating Spring Force	Self Inductance	Insertion Loss < -1db to	Typical Contact Resistance	Maximum Current
<a href="#">A1512</a>	.131"	3.32	.119"	3.02	18-29g	0.66 nH	20.3 GHz	72 mOhms	2.0 A
<a href="#">A1520</a>	.081"	2.05	.075"	1.90	20g	0.44 nH	24.1 GHz	60 mOhms	2.0 A
<a href="#">A1540</a>	.126"	3.20	.114"	2.90	22-29g	0.42 nH	16.1 GHz	20 mOhms	4.3 A
<a href="#">A1550</a>	.133"	3.30	.118"	3.00	20-29g	0.71 nH	18.7 GHz	85 mOhms	2.0 A
<a href="#">A1561</a>	.149"	3.78	.131"	3.33	16-29g	0.67 nH	7.4 GHz	90 mOhms	1.65 A
<a href="#">A1562</a>	.160"	4.06	.144"	3.66	14-30g	0.80 nH	11.6 GHz	90 mOhms	1.45 A
<a href="#">A1580</a>	.210"	5.33	.192"	4.88	16-32g	1.02 nH	7.4 GHz	95 mOhms	1.55 A
<a href="#">A1582</a>	.210"	5.33	.184"	4.67	16-30g	0.93 nH	9.6 GHz	100 mOhms	1.4 A
<a href="#">A1586</a>	.219"	5.56	.199"	5.06	19-20g	-	-	-	-

**MECHANICAL DIMENSIONS  
INCHES [MM]**

Signal Integrity, Inc.

104 County Street, Ste. 210, Attleboro, MA 02703

Tel: 1-508-226-6480 Fax: 1-508-226-6488 Internet: [www.signalin.com](http://www.signalin.com)

Signal Integrity makes no representation that the use of its products described herein, or the use of other technical information contained herein, will not infringe on existing or future patent rights. The descriptions contained herein do not imply the granting of licenses to make, use, or sell equipment constructed in accordance therewith. Specifications are subject to change without notice.