

FEATURES

- <-1db insertion loss to 6.4GHz
- <2:1VSWR to 5.6GHz
- 28g operating spring force
- $Z_0 = 33.1\Omega$
- <40.5ps risetime
- 80milliOhms contact resistance
- 2.6A max drive current

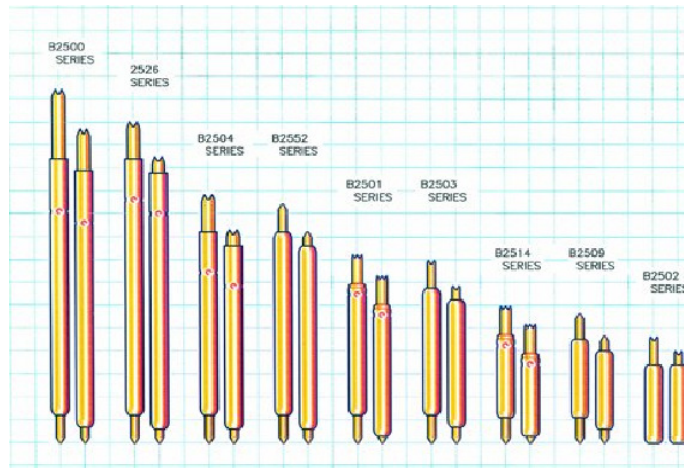

GENERAL DESCRIPTION

The B2500 series spring probes from Signal Integrity Inc. are designed to meet the rigorous test requirements driven by the fast risetimes and increased need for RF and wireless bandwidth in the high volume, very fine pitch test socket market. Along with speed and accuracy, these probes are designed to operate at pitches down to 0.5mm, specifically tailored to the ultra fine packaging these markets demand.

The high bandwidth of these probes provides very low insertion loss up to 6.4GHz. These probes will provide transparent operation on Bluetooth, 802.11b and 3G wireless protocol devices and exceed the test probe requirements for fine pitch SOC devices, ASIC devices, microwave communications devices and system interconnects.

With an impulse risetime of less than 40.5ps and a propagation delay of 39ps, the B2500 Series is designed for building transparent test channels or interconnect solutions that must address the signal performance needed in data communications and source synchronous memory busses up to 5Gb/s.

SERIES B2500 ORDERING INFORMATION

B Series 0.5mm (.0197inch) Pitch				
Model	Length Operating /Initial Inches [mm]	DUT Plunger and Plating	Spring	Operating Spring Force
B2500-A1	.275 [6.99] / .304[7.72]	4 Point Serrated - Gold – Tool Steel	Stainless Steel	28 Grams
B2500-F6		Conic - Gold - BeCu	Stainless Steel	28 Grams
B2500-H8		Spherical - Gold - BeCu	Stainless Steel	28 Grams
B2500-J1		Red Crown – Palladium – Tool Steel	Stainless Steel	28 Grams
B2500-K2		Reduced Crown – Gold – Tool Steel	Stainless Steel	28 Grams
B2500-L3		Spherical – Palladium - BeCu	Stainless Steel	28 Grams
B2500-N5		Spherical – Gold - BeCu	Stainless Steel	21 Grams

FUNCTIONAL SPECIFICATIONS

Model	B2500-K2			
Time Domain	Min.	Typ.	Max.	Units
TDT Risettime into 50Ω			40.5	ps
TDR Risettime open circuit			60.0	ps
TDR Risettime short circuit			102.0	ps
Signal Delay into 50Ω		39.0		ps
Frequency Domain				
Insertion Loss <-1db	6.4			GHz
<-3db	26.1			GHz
Return Loss, S11 <-10db	6.9			GHz
<-20db	1.5			GHz
VSWR <2:1	21.5			GHz
Equivalent Circuit Parameters				
Pin Inductance		1.73		nH
Pin Capacitance to ground		0.51		pF
Mutual Inductance		0.29		nH
Mutual Capacitance		0.21		pF
Transmission Line Zo		33.1		Ω
Tl		39.0		ps
DC Parameters				
Contact Resistance		80		mΩ
Maximum Rating				
Drive Current		2.6		A

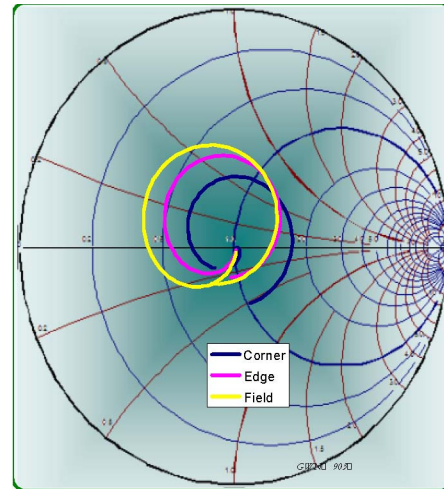

Figure 2: Measurement into 50Ω, B2500-K2

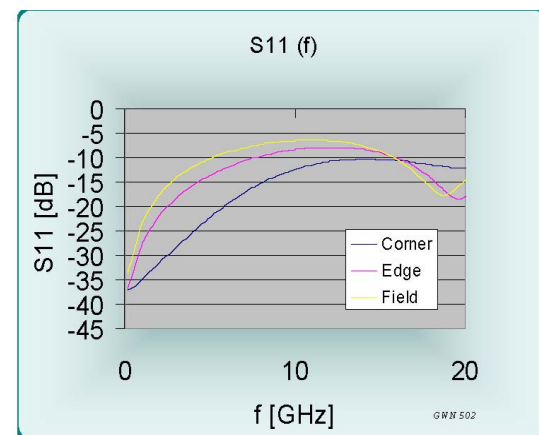

Figure 3: Return Loss, S11, B2500-K2

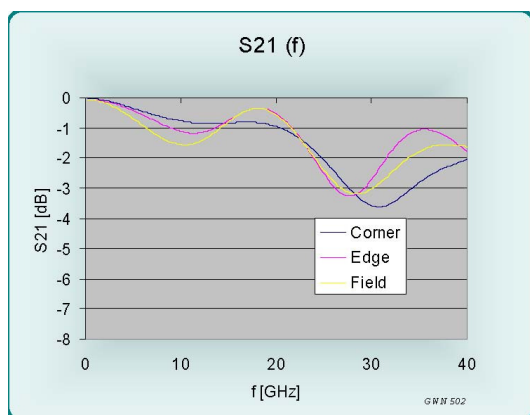

Figure 1: Insertion Loss, S21, B2500-K2

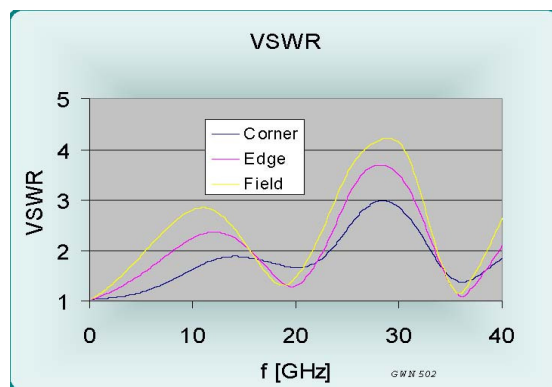

Figure 4: VSWR, B2500-K2

EQUIVALENT CIRCUITS / SPICE MODELS

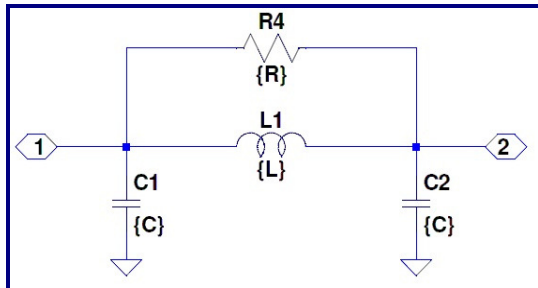

Figure 5: Pi Equivalent, Valid to <5GHz

C1, C2	0.510	pF
L1	1.73	nH
R4	700	Ohms

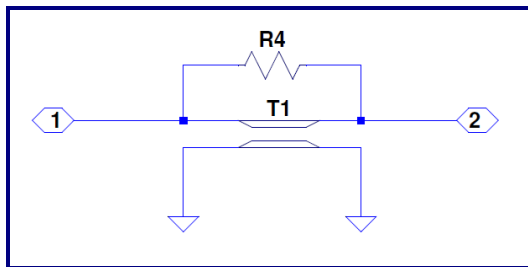

Figure 6: Transmission Line Model, Valid to >20GHz

Z0	44.2	Ohms
T1	45.08	ps
R4	1000	Ohms

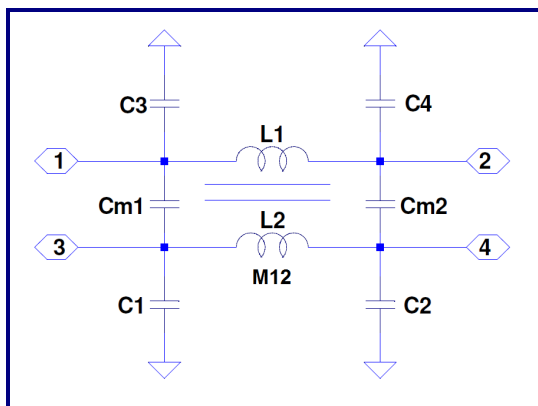

Figure 7: Lumped, Mutual Elements

C1,2,3,4	0.510	pF
Cm1, Cm2	0.210	pF
L1, L2	1.73	nH
M12	0.293	nH

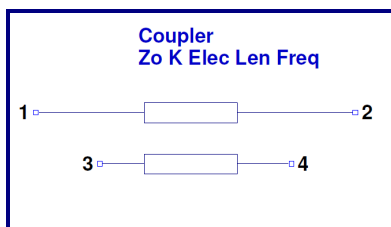
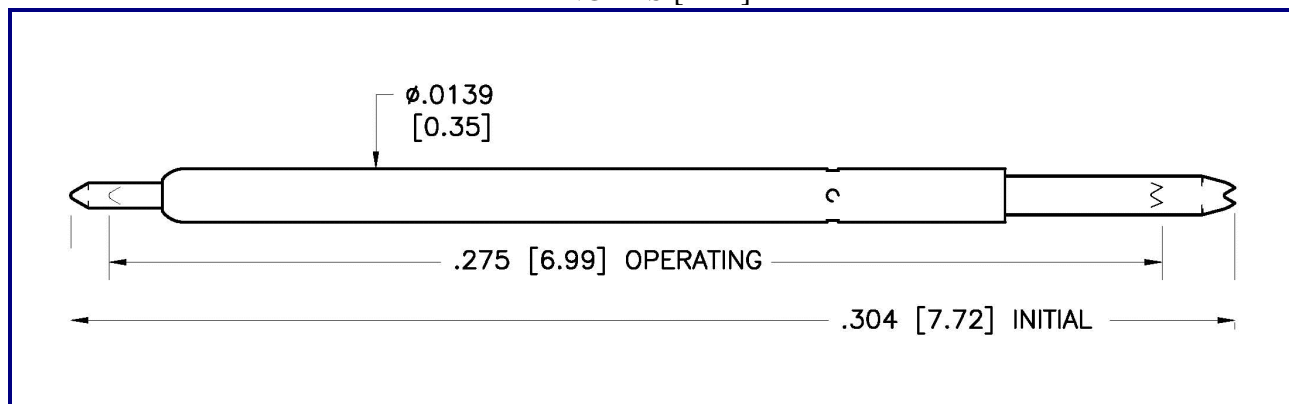

Figure 8: Transmission Line Equivalent for Crosstalk

Z0	33.1	Ohms
T1	39.0	ps

B SERIES MODELS

B Series 0.5mm (.0197 inch) Pitch									
Probe Series	Initial Length inch / mm		Operating Position inch / mm		Spring Force	Self Inductance	Insertion Loss <-1db to	Typical Contact Resistance	Maximum Current
B2500	.304"	7.72	.275"	6.99	28 g	1.73 nH	6.4 GHz	80 mOhms	2.6 A
B2501	.162"	4.11	.150"	3.81	20-35 g	0.97 nH	11.2 GHz	50 mOhms	2.8 A
B2502	.091"	2.31	.085"	2.16	32 g	0.54 nH	17.0 GHz	30 mOhms	1.5 A
B2503	.157"	3.99	.142"	3.61	26-32 g	0.71 nH	13.0 GHz	60 mOhms	1.7 A
B2504	.214"	5.42	.190"	4.82	24-34 g	1.12 nH	8.8 GHz	60 mOhms	2.9 A
B2509	.108"	2.74	.094"	2.39	26 g	0.60 nH	13.2 GHz	90 mOhms	2.0 A
B2514	.116"	2.95	.104"	2.64	26 g	0.63 nH	12.2 GHz	90 mOhms	2.0 A
B2535	.217"	5.50	.199"	5.05	26-31 g	~	~	55 mOhms	2.3 A

MECHANICAL DIMENSIONS
 INCHES [MM]

Signal Integrity, Inc.
 104 County Street, Ste. 210, Attleboro, MA 02703
 Tel: 1-508-226-6480 Fax: 1-508-226-6488 Internet: www.signalin.com

Signal Integrity makes no representation that the use of its products described herein, or the use of other technical information contained herein, will not infringe on existing or future patent rights. The descriptions contained herein do not imply the granting of licenses to make, use, or sell equipment constructed in accordance therewith. Specifications are subject to change without notice.