

FEATURES

- <-1db insertion loss to 8.8GHz
- <2:1VSWR to 7.97GHz
- 28g operating spring force
- $Z_0 = 38.3\Omega$
- <39ps risetime
- 60milliOhms contact resistance
- 2.9Amps max. drive current

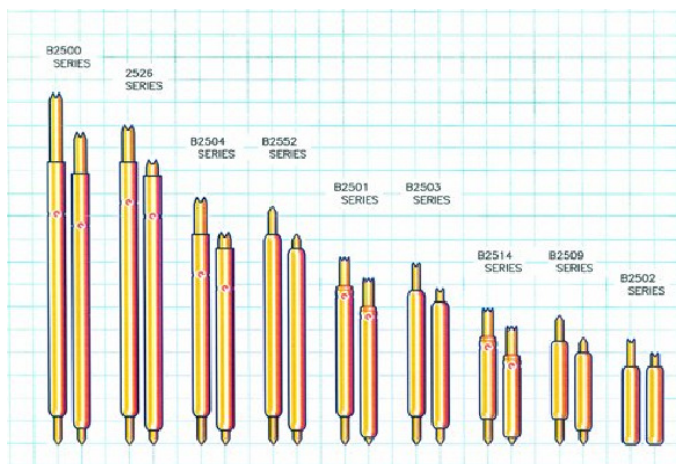

GENERAL DESCRIPTION

The B2504 series spring probes from Signal Integrity Inc. are designed to meet the rigorous test requirements driven by the ultra fast risetimes in the digital domain, and high bandwidth, high frequency RF / microwave specifications for the wireless market. Along with speed and accuracy, these probes are designed to operate at pitches to 0.5mm, specifically for the ultra fine pitch packaging these markets demand.

The ultra high bandwidth of these probes provides very low insertion loss up to 8.8GHz. These probes will provide transparent operation on Bluetooth, 802.11b and 3G wireless protocol devices as well as exceed the test probe demands of proprietary microwave communications devices and systems.

With an impulse risetime of less than 39ps and a propagation delay of 31.5ps, the B2504 has more than enough performance for probe applications and interconnection solutions in broadband digital. These probes are ideal for building transparent test channels or interconnection solutions that must address datacom and source synchronous memory busses. Among others, these include Infiniband, PCI-Express, Source Synchronous DDR, Rambus[™], HyperTransport and 10Gb Ethernet.

SERIES B2504 MODELS: ORDERING INFORMATION

B Series 0.5mm (.0197inch) Pitch					
Model	Length Operating /Initial inches [mm]	DUT Plunger and Plating	Interface Plunger	Spring	Operating Force
B2504-B2	.193 [4.9] / .216 [5.49]	Crown - Gold	Conic	Music Wire	28 Grams
B2504-J9		Crown - Gold			40 Grams
B2504-K1		Crown - Gold			38 Grams
B2504-L3		Conic - Gold			38 Grams
B2504-M4		Crown - Gold			50 Grams
B2504-R8		Conic - Gold		Stainless Steel	28 Grams

FUNCTIONAL SPECIFICATIONS

Model	B2504-C3			
Time Domain	Min.	Typ.	Max.	Units
TDT Risetime into 50Ω			39.0	ps
TDR Risetime open circuit			52.5	ps
TDR Risetime short circuit			51.0	ps
Signal Delay into 50Ω		31.5		ps
Frequency Domain				
Insertion Loss <-1.0db	8.8			GHz
<-3.0db	33.08			GHz
Return loss <-10db	8.0			GHz
VSWR <2:1	7.97			GHz
Equivalent Circuit Parameters				
Pin Inductance		1.12		nH
Pin Capacitance to ground		0.62		pF
Transmission Line Zo		38.3		Ohm
Tl		28.0		ps
DC Parameters				
Contact Resistance		60		milli Ohm
Maximum Rating				
Drive Current		2.9		A

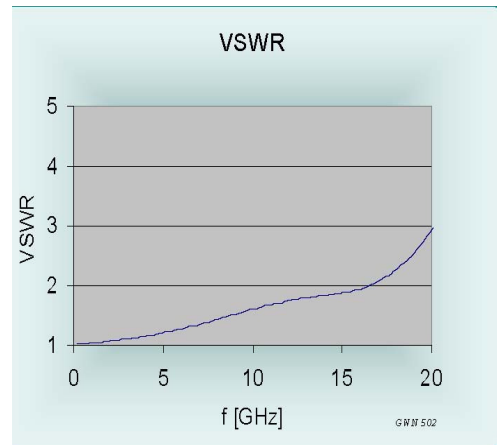

Figure 2: VSWR, B2504-C3

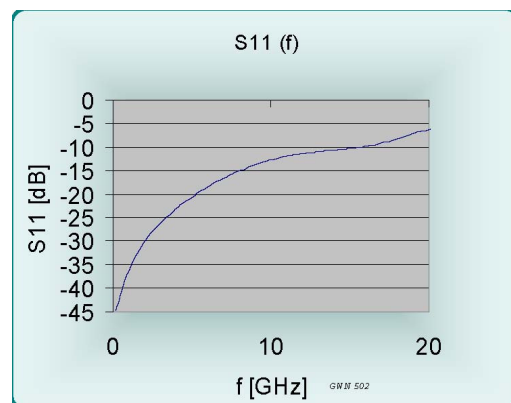

Figure 3: Return Loss, S11, B2504-C3

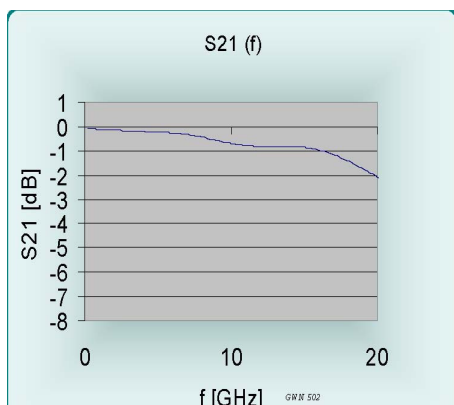

Figure 1: Insertion Loss, S21, B2504-C3

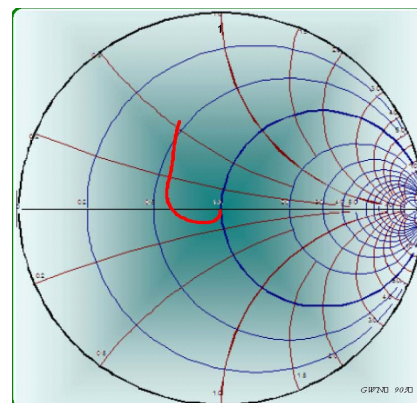

Figure4: B2504-C3, Into 50Ω

EQUIVALENT CIRCUITS / SPICE MODELS

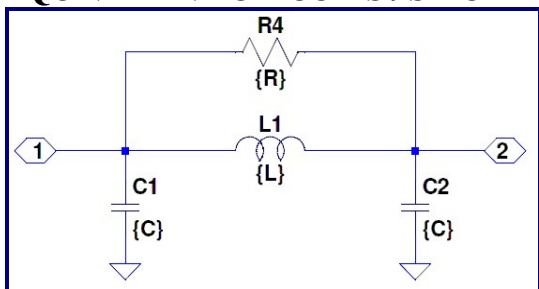

Figure 5: Pi Equivalent, Valid to 8GHz

C1, C2	0.382	pF
L1	0.97	nH
R4	700	Ohms

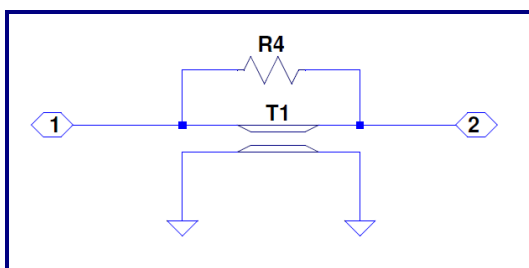

Figure 6: Transmission Line Model

Z0	38.3	Ohms
L	28.0	ps
R4	2,000	Ohms
L2	0.15	nH
L3	0.35	nH

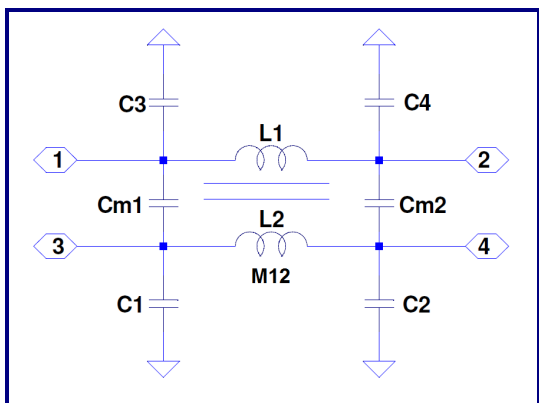

Figure 7: Lumped, Mutual Elements

C1,2,3,4	0.382	pF
Cm1, Cm2	0.134	pF
L1, L2	1.12	nH
M12	0.200	nH

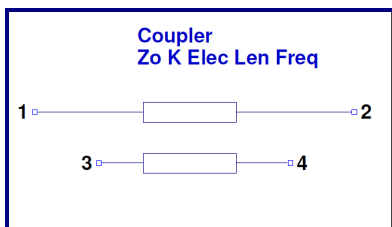
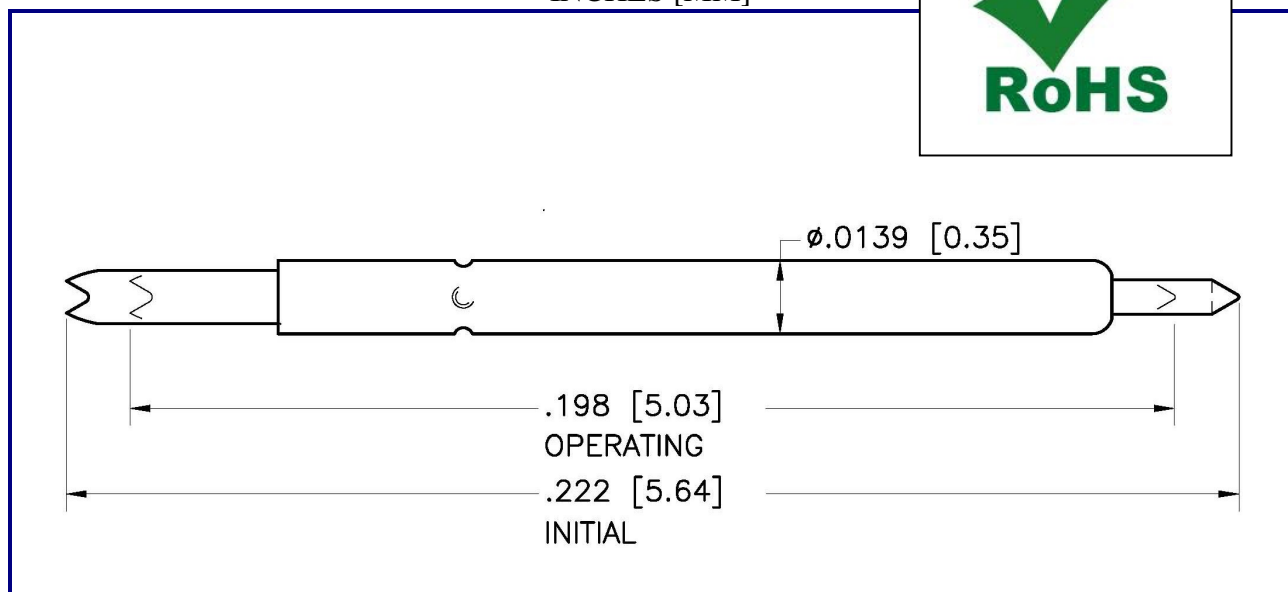

Figure 8: Transmission Line Equivalent for Crosstalk

Z0	33.4	Ohms
Tl	31.5	ps
K	0.18	
F	15.9	GHz

B SERIES MODELS
B Series 0.5mm (.0197 inch) Pitch

Probe Series	Initial Length inch / mm		Operating Position inch / mm		Spring Force	Self Inductance	Insertion Loss <-1db to	Typical Contact Resistance	Maximum Current
B2500	.304"	7.72	.275"	6.99	28 g	1.73 nH	6.4 GHz	80 mOhms	2.6 A
B2501	.162"	4.11	.150"	3.81	20-35 g	0.97 nH	11.2 GHz	50 mOhms	2.8 A
B2502	.091"	2.31	.085"	2.16	32 g	0.54 nH	17.0 GHz	30 mOhms	1.5 A
B2503	.157"	3.99	.142"	3.61	26-32 g	0.71 nH	13.0 GHz	60 mOhms	1.7 A
B2504	.214"	5.42	.190"	4.82	24-34 g	1.12 nH	8.8 GHz	60 mOhms	2.9 A
B2509	.108"	2.74	.094"	2.39	26 g	0.60 nH	13.2 GHz	90 mOhms	2.0 A
B2514	.116"	2.95	.104"	2.64	26 g	0.63 nH	12.2 GHz	90 mOhms	2.0 A
B2535	.217"	5.50	.199"	5.05	26-31 g	~	~	55 mOhms	2.3 A

MECHANICAL DIMENSIONS
 INCHES [MM]

Signal Integrity, Inc.

104 County Street, Suite 210, Attleboro, MA 02703

 Tel: 1-508-226-6480 Fax: 1-508-226-6488 Internet: www.signalin.com

Signal Integrity makes no representation that the use of its products described herein, or the use of other technical information contained herein, will not infringe on existing or future patent rights. The descriptions contained herein do not imply the granting of licenses to make, use, or sell equipment constructed in accordance therewith. Specifications are subject to change without notice.