

FEATURES

- <-1db insertion loss to 13.2 GHz
- <2:1 VSWR to 14.7 GHz
- 26g operating spring force
- $Z_0 = 34.9 \Omega$
- <34.5 ps risetime
- 90 milliOhms contact resistance
- 2.0 Amps max. drive current

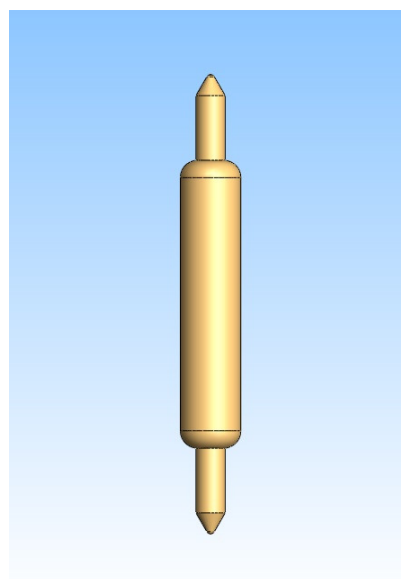

GENERAL DESCRIPTION

The B2509 spring probe from Signal Integrity Inc. is designed to meet the rigorous test requirements driven by the ultra fast risetimes in the digital domain, and high bandwidth, high frequency RF / microwave specifications for the wireless market. Along with speed and accuracy, these probes are designed to operate at pitches to 0.5mm, specifically for the ultra fine pitch packaging these markets demand.

The ultra high bandwidth of these probes provides very low insertion loss up to 13.2GHz. These probes will provide transparent operation on Bluetooth, 802.11b and 3G wireless protocol devices as well as exceed the test probe demands of proprietary microwave communications devices and systems.

SERIES B2509 MODELS: ORDERING INFORMATION

B Series 0.5mm (.0197inch) Pitch					
Model	Length Operating /Initial inches [mm]	DUT Plunger	Interface Plunger	Spring	Operating Spring Force
B2509-A1	.094 [2.39]/.108 [2.74]	Conic - Gold	Conic - Gold	Music Wire	26 Grams
B2509-C3		Conic - Gold	Conic - Gold	Stainless Steel	
B2509-D4		Crown - Gold	Conic - Gold	Music Wire	
B2509-E5		Crown - Gold	Spherical - Gold	Stainless Steel	
B2509-F6		Crown - Gold	Crown - Gold	Music Wire	

FUNCTIONAL SPECIFICATIONS

Model	B2509-F6			
Time Domain	Min.	Typ.	Max.	Units
TDT Risetime into 50Ω			34.5	ps
TDR Risetime open circuit			46.5	ps
TDR Risetime short circuit			34.5	ps
Signal Delay into 50Ω		16.8		ps
Frequency Domain				
Insertion Loss <-1db	13.2			GHz
<-3db	>40			GHz
Return Loss, S11 <-20db	4.0			GHz
VSWR <2:1	14.7			GHZ
Equivalent Circuit Parameters				
Pin Inductance		0.60		NH
Pin Capacitance to ground, C1, C2		0.233		pF
Mutual Inductance		0.122		nH
Mutual Capacitance		0.042		pF
Transmission Line Zo		34.9		Ω
Tl		16.8		ps
DC Parameters		B2509-A1		
Contact Resistance		90		mΩ
Maximum Rating				
Drive Current		2.0		A

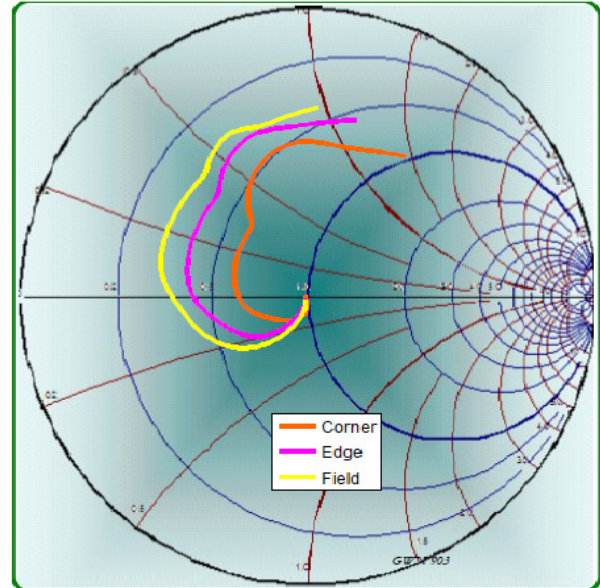

Figure 2: Measurement into 50Ω, B2509-F6

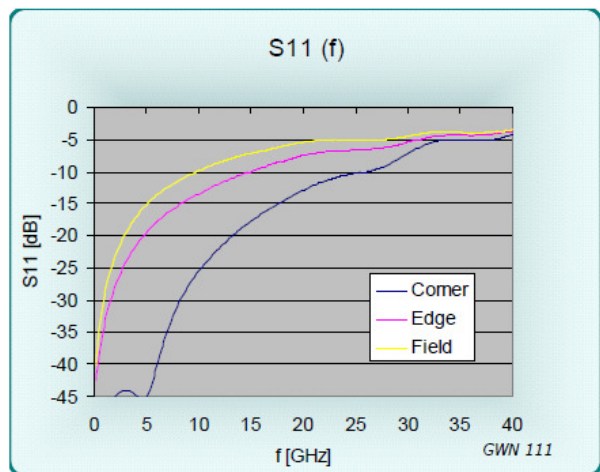

Figure 3: Return Loss, S11, B2509-F6

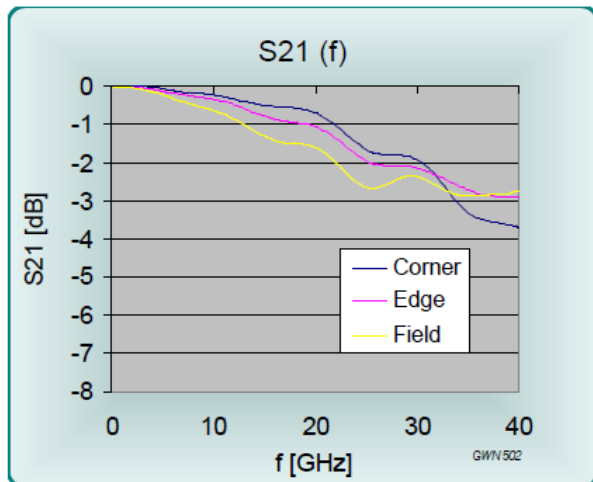

Figure 1: Insertion Loss, S21, B2509-F6

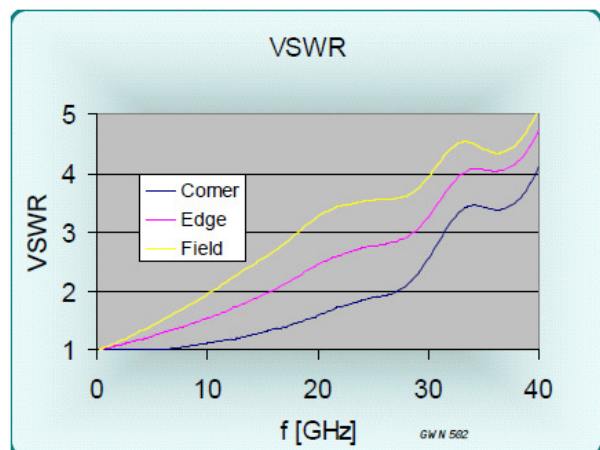

Figure 4: VSWR, B2509-F6

EQUIVALENT CIRCUITS / SPICE MODELS

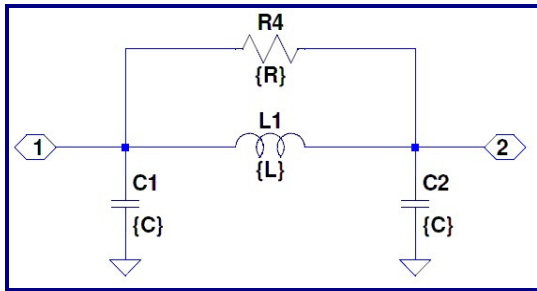

Figure 5: Pi Equivalent, Valid to 14GHz

Site	Cg = C1+C2	L1	R4
Corner	0.349 pF	0.80 nH	1000 Ω
Edge	0.414 pF	0.69 nH	700 Ω
Field	0.467 pF	0.60 nH	300 Ω
Diagonal	0.467 pF	0.60 nH	300 Ω

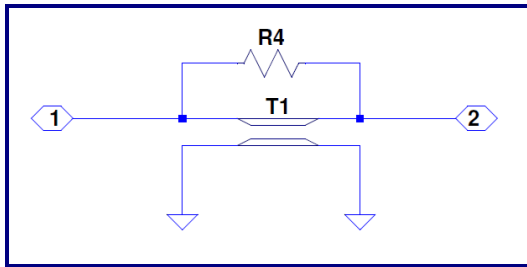

Figure 6: Transmission Line Model Valid to >40GHz

Site	Zo	L	R4
Corner	48.0 Ω	16.75 ps	1000 Ω
Edge	30.9 Ω	16.92 ps	1000 Ω
Field	35.9 Ω	16.74 ps	1000 Ω

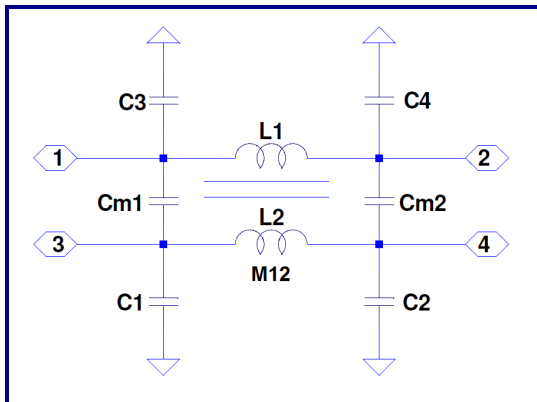

Figure 7: Lumped, Mutual Elements

Site	C1,2,3,4	Cm1,Cm2	L1,L2	M
Corner	0.174	0.051 pF	0.80	0.242 nH
Edge	0.207	0.047 pF	0.69	0.174 nH
Field	0.233	0.042 pF	0.60	0.122 nH
Diagonal	0.233	0.006 pF	0.60	0.077 nH

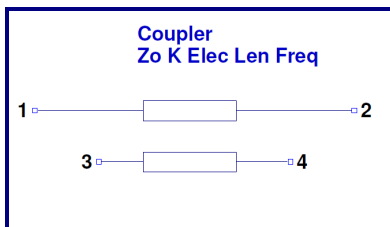
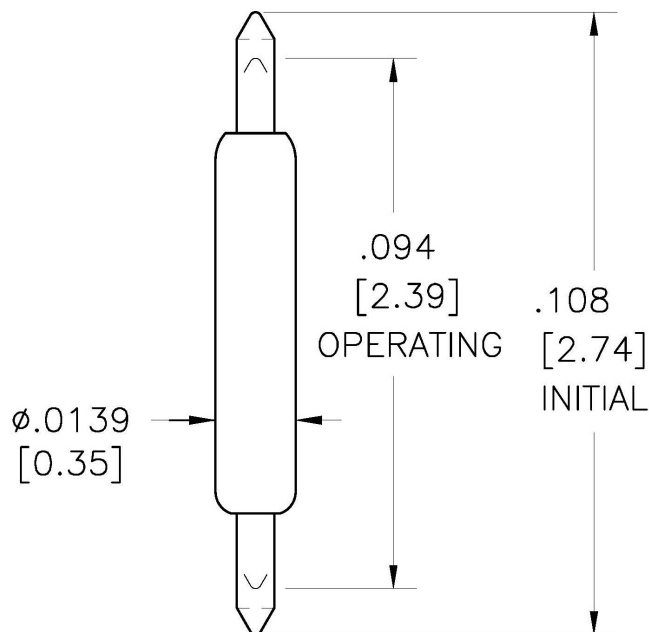

Figure 8: Transmission Line Equivalent for Crosstalk

Z0	L1	k	f
34.9 Ω	16.8 ps	0.20	29.9 GHz

B Series 0.5mm (.0197 inch) Pitch

Probe Series	Initial Length inch / mm		Operating Position inch / mm		Spring Force	Self Inductance	Insertion Loss <-1db to	Typical Contact Resistance	Maximum Current
B2500	.304"	7.72	.275"	6.99	28 g	1.73 nH	6.4 GHz	80 mOhms	2.6 A
B2501	.162"	4.11	.150"	3.81	20-35 g	0.97 nH	11.2 GHz	50 mOhms	2.8 A
B2502	.091"	2.31	.085"	2.16	32 g	0.54 nH	17.0 GHz	30 mOhms	1.5 A
B2503	.157"	3.99	.142"	3.61	26-32 g	0.71 nH	13.0 GHz	60 mOhms	1.7 A
B2504	.214"	5.42	.190"	4.82	24-34 g	1.12 nH	8.8 GHz	60 mOhms	2.9 A
B2509	.108"	2.74	.094"	2.39	26 g	0.60 nH	13.2 GHz	90 mOhms	2.0 A
B2514	.116"	2.95	.104"	2.64	26 g	0.63 nH	12.2 GHz	90 mOhms	2.0 A
B2535	.217"	5.50	.199"	5.05	26-31 g	~	~	55 mOhms	2.3 A

**MECHANICAL DIMENSIONS
INCHES [MM]**

Signal Integrity, Inc.

104 County Street, Ste. 210, Attleboro, MA 02703

Tel: 1-508-226-6480 Fax: 1-508-226-6488 Internet: www.signalin.com

Signal Integrity makes no representation that the use of its products described herein, or the use of other technical information contained herein, will not infringe on existing or future patent rights. The descriptions contained herein do not imply the granting of licenses to make, use, or sell equipment constructed in accordance therewith. Specifications are subject to change without notice.