

FEATURES

- <-1db insertion loss to 38.5 GHz
- <2:1 VSWR to >40GHz
- Z0 = 42.8Ω
- <31.5ps risetime
- 20 milliOhms contact resistance
- 6 Amps max. drive current

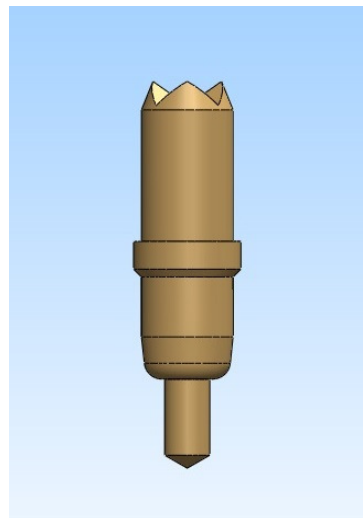

GENERAL DESCRIPTION

The D4525 spring probe from Signal Integrity Inc. is designed to meet the rigorous test requirements driven by the ultra fast risetimes in the digital domain, and high bandwidth, high frequency RF / microwave specifications for the wireless market. Along with speed and accuracy, these probes are designed to operate at pitches to 0.8mm, specifically for the ultra fine pitch packaging these markets demand.

The ultra high bandwidth of these probes provides very low insertion loss up to 38.5GHz. These probes will provide transparent operation on Bluetooth, 802.11b and 3G wireless protocol devices as well as exceed the test probe demands of proprietary microwave communications devices and systems.

SERIES D4525 MODELS: ORDERING INFORMATION

D Series 0.8mm (.0315 inch) Pitch Inches [MM]				
Model	Length Operating / Initial inches [mm]	DUT Plunger and Plating	Spring	Operating Spring Force
D4525-A1	.071 [1.80] / .087 [2.21]	Reduced Crown - Gold	Music Wire	30 Grams
D4525-B2		Conic 120 - Gold		
D4525-E5		Sharp Conic - Gold		
D4525-D4		Reduced Crown - Gold	Stainless Steel	25 Grams
D4525-F6		Conic 120- Gold		
D4525-G7		Conic 90 - Gold		
D4525-H8		Reduced Crown - Pd		
D4525-S1		Sharp Conic - Gold		

FUNCTIONAL SPECIFICATIONS

Model	D4525-A1			
Time Domain	Min.	Typ.	Max.	Units
TDT Risetime into 50Ω			31.5	ps
TDR Risetime open circuit			31.5	ps
TDR Risetime short circuit			36.0	ps
Signal Delay into 50Ω		11.6		ps
Frequency Domain				
Insertion Loss <-1db	20.9		38.5	GHz
<-3db	>40.0			GHz
Return Loss, S11 <-10db	40.0			GHz
<-20db	17.1			GHz
VSWR <2:1	27.5		>40.0	GHZ
Equivalent Circuit Parameters				
Pin Inductance		0.48		NH
Pin Capacitance to ground, C1, C2		0.134		pF
Mutual Inductance		0.090		nH
Mutual Capacitance		0.042		pF
Transmission Line Zo		42.8		Ω
Tl		11.6		ps
DC Parameters				
Contact Resistance		20		mΩ
Maximum Rating				
Drive Current		6.0		A

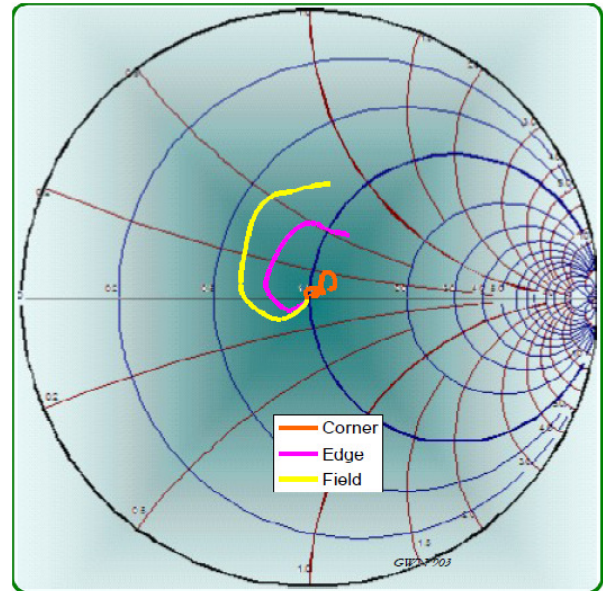

Figure 2: Measurement into 50Ω, D4525-A1

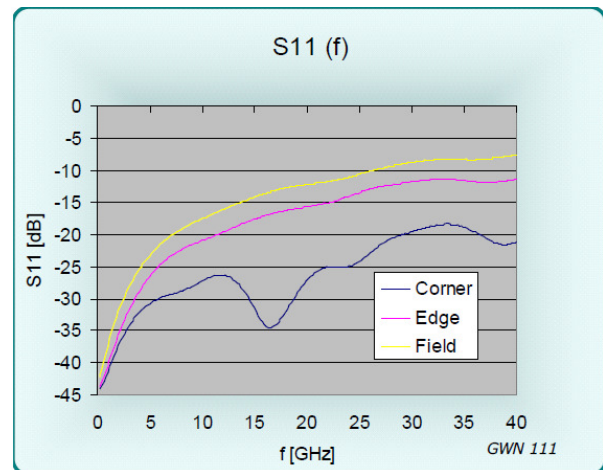

Figure 3: Return Loss, S11, D4525-A1

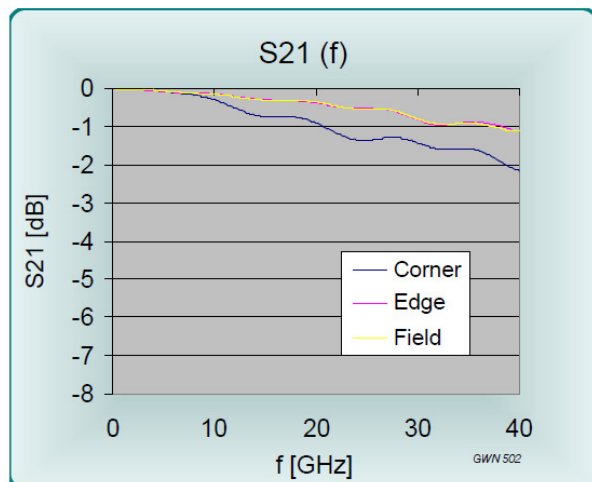

Figure 1: Insertion Loss, S21, D4525-A1

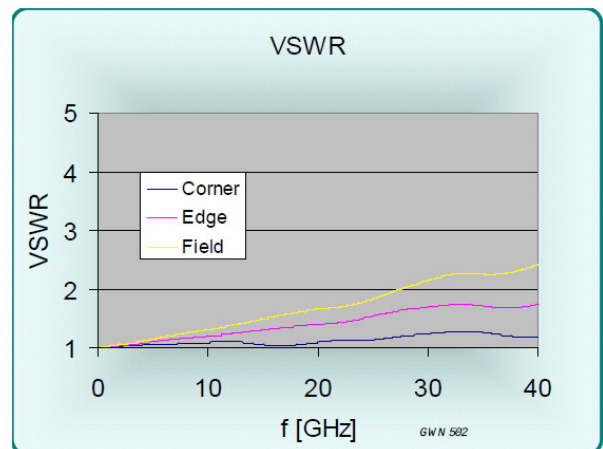

Figure 4: VSWR, D4525-A1

EQUIVALENT CIRCUITS / SPICE MODELS

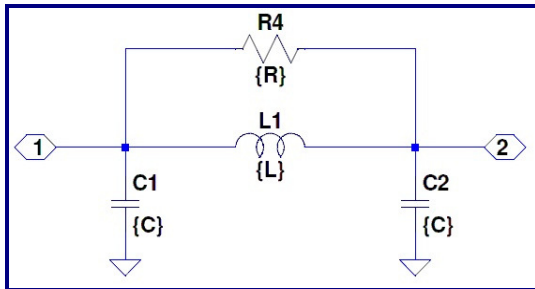

Figure 5: Pi Equivalent, Valid to 19GHz

Site	Cg = C1+C2	L1	R4
Corner	0.232 pF	0.65 nH	900 Ω
Edge	0.252 pF	0.52 nH	800 Ω
Field	0.268 pF	0.48 nH	700 Ω
Diagonal	0.268 pF	0.48 nH	700 Ω

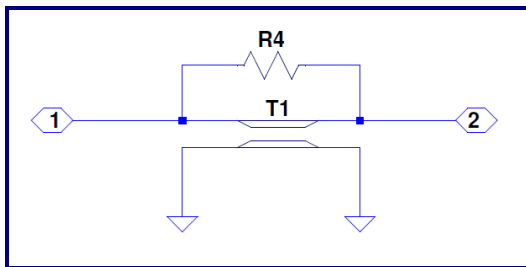

Figure 6: Transmission Line Model Valid to >40GHz

Site	Zo	L	R4
Corner	52.8 Ω	12.23 ps	800 Ω
Edge	45.3 Ω	11.44 ps	2000 Ω
Field	42.2 Ω	11.32 ps	3000 Ω

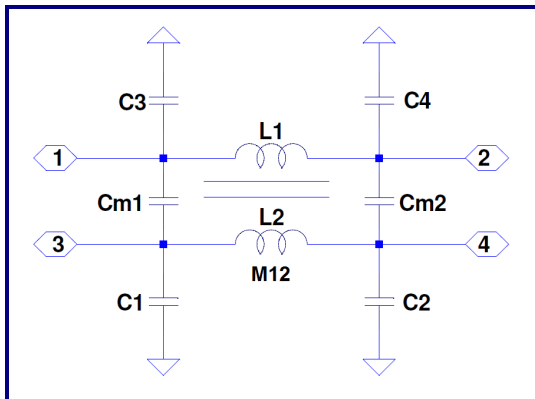

Figure 7: Lumped, Mutual Elements

Site	C1,2,3,4	Cm1,Cm2	L1,L2	M
Corner	0.116	0.030 pF	0.65	0.167 nH
Edge	0.126	0.025 pF	0.52	0.138 nH
Field	0.134	0.021 pF	0.48	0.090 nH
Diagonal	0.134	0.004 pF	0.48	0.021 nH

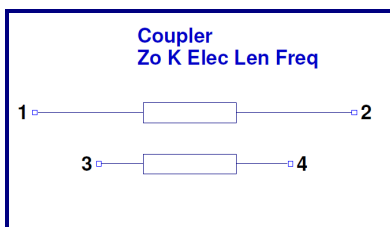
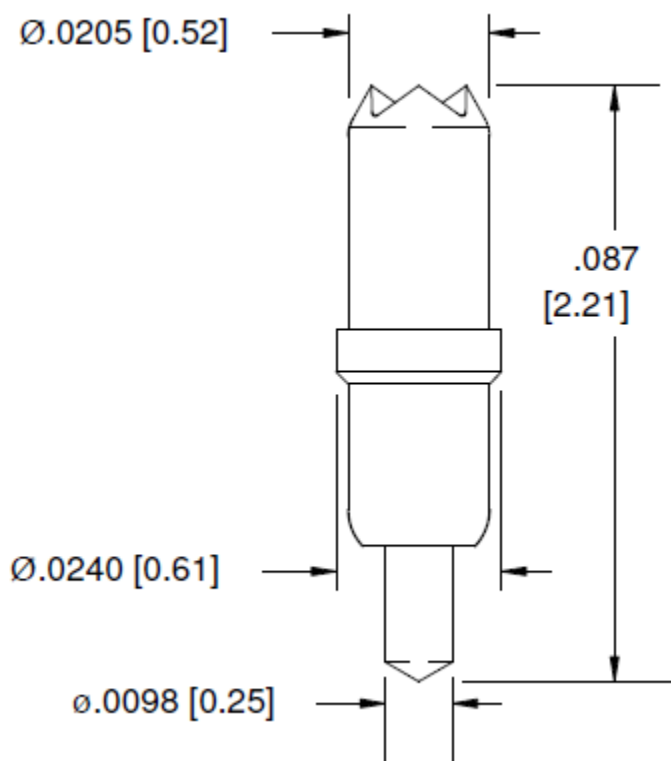

Figure 8: Transmission Line Equivalent for Crosstalk

Z0	L1	k	f
42.8 Ω	11.6 ps	0.19	44.2 GHz

D Series 0.8mm (.0315) pitch									
Probe Series	Initial Length		Operating Position		Spring Force	Self Inductance	Insertion Loss < -1db to	Typical Contact Resistance	Maximum Current
	inch/mm		inch/mm						
D4525	.087"	2.21	.071"	1.80	30 g	0.48 nH	38.5 GHz	20 mOhms	6.0 A
D4565	.092"	2.33	.071"	1.80	30 g	0.5 nH	17.0 GHz	25 mOhms	6.0 A
D4595	.154"	3.91	.128"	3.25	38 g	0.82 nH	19.5 GHz	30 mOhms	3.0 A
D4601	.214"	5.43	.186"	4.72	24-34 g	1.0 nH	12.8 GHz	50 mOhms	6.0 A
D4603	.209"	5.30	.181"	4.59	24 g	1.16 nH	12.4 GHz	70 mOhms	4.0 A
D4613	.249"	6.32	.213-.216"	5.49	24-34 g	1.25 nH	14.3 GHz	40 mOhms	2.15 A
D4623	.289"	7.33	.253"	6.43	34 g	1.55 nH	8.2 GHz	60 mOhms	5.4 A
D4823	.289"	7.33	.253"	6.43	28 g	-	-	-	-
D4693	.185"	4.71	.157"	4.00	24-34 g	0.92 nH	18.3 GHz	40 mOhms	3.0 A
D4694	.185"	4.71	.157"	4.00	23-36 g	0.80 nH	7.8 GHz	40 mOhms	3.0 A
D4697	.339"	8.61	.295"	7.50	32 g	2.01 nH	8.6 GHz	45 mOhms	2.6 A

MECHANICAL DIMENSIONS
INCHES [MM]



Signal Integrity, Inc.

104 County Street, Ste. 210, Attleboro, MA 02703

Tel: 1-508-226-6480 Fax: 1-508-226-6488 Internet: www.signalin.com

Signal Integrity makes no representation that the use of its products described herein, or the use of other technical information contained herein, will not infringe on existing or future patent rights. The descriptions contained herein do not imply the granting of licenses to make, use, or sell equipment constructed in accordance therewith. Specifications are subject to change without notice.