

FEATURES

- <-1db insertion loss 8.6 GHz
- <2:1 VSWR to 8.4 GHz
- 16-32g operating spring force
- $Z_0 = 39.3 \Omega$
- <42 ps risetime
- 45 milliohms
- 2.6 Amps max drive current

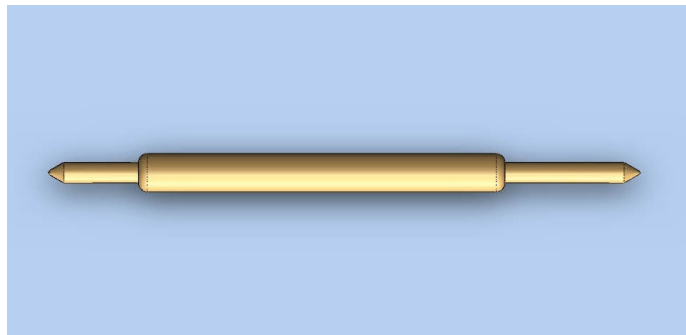

GENERAL DESCRIPTION

The D4697 series spring probes from Signal Integrity Inc. are designed to meet the rigorous test probe bandwidth of the wireless and RF test markets as well as very fast rise times in test applications for telecommunication and broadband data communications system-on-a-chip devices. The risetime requirements for these devices are usually well below 150 picoseconds. Along with speed and accuracy, these probes are designed for testing very fine pitch to 0.8mm, well suited to the packaging constraints driven by the consumer wireless market.

The high bandwidth of these probes provides very low insertion loss up to 8.6GHz. These probes will provide transparent operation on Bluetooth, 802.11b and 3G wireless protocol devices as well as exceed the test probe demands of proprietary microwave communications devices and systems.

With an impulse risetime of less than 42 ps and a propagation delay of 40.9ps, the AC performance of the D4697 probe is transparent for test applications and interconnections solutions that operate in high speed CMOS, SiGe and GaAs technologies.

SERIES D4697 MODELS: ORDERING INFORMATION

D Series 0.8mm (.0315inch) Pitch				
Model	Length Operating / Initial inches [mm]	DUT Plunger and Plating	Spring	Operating Spring Force
D4697-B2	.295 [7.50] / .339 [8.61]	Conic – Gold	Stainless Steel	32 Grams
D4697-C3		Reduced Crown - Gold		
D4697-D4				Crown - Gold
D4697-G7				

FUNCTIONAL SPECIFICATIONS

Model	D4697-B2			Units
	Corner	Edge	Field	
TDT Risettime thru 50Ω	38	36	42	ps
TDR Risettime open circuit	34	56	66	ps
TDR Risettime short circuit	126	38	80	ps
Signal Delay into 50Ω	42.2	41.0	40.9	ps
Insertion Loss <-1db	11.2	10.6	8.6	GHz
Insertion Loss <-3db	26.3	27.7	28.1	GHz
VSWR <2:1	11.4	10.6	8.4	GHz

Equivalent Circuit Parameters

	Min.	Typ.	Max.	Units
Pin Inductance		2.01		nH
Pin Capacitance		.984		pF
Mutual Inductance		.304		nH
Mutual Capacitance		.067		pF
Transmission Line				
Zo		39.3		Ω
Tl		40.9		ps

MAXIMUM DC CURRENT

DUTY CYCLE	DC	50%	25%	10%	1%
AMPS	2.67	3.74	4.72	5.84	6.94

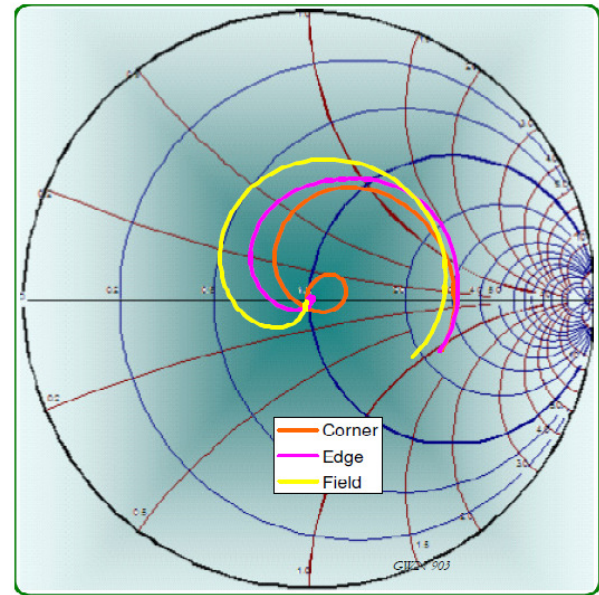

Figure 2: Measurement into 50Ω, D4697-B2

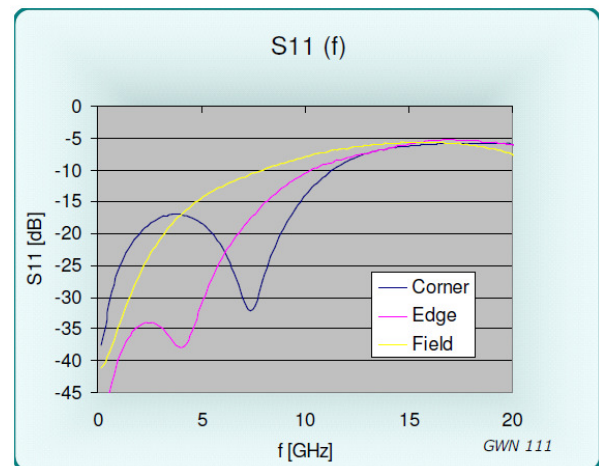

Figure 3: Return Loss, S11, D4697-B2

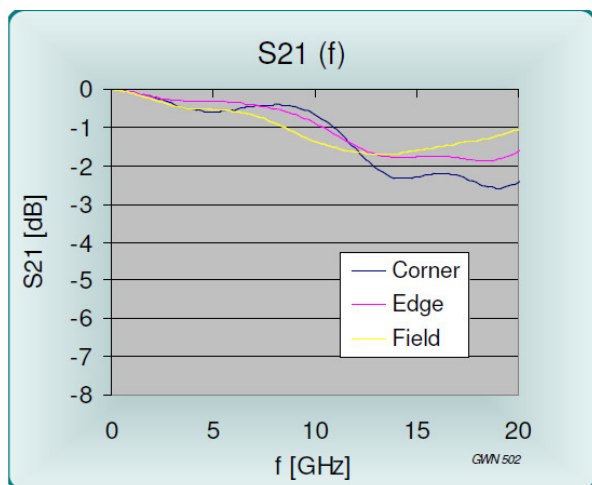

Figure 1: Insertion Loss, S21, D4697-B2

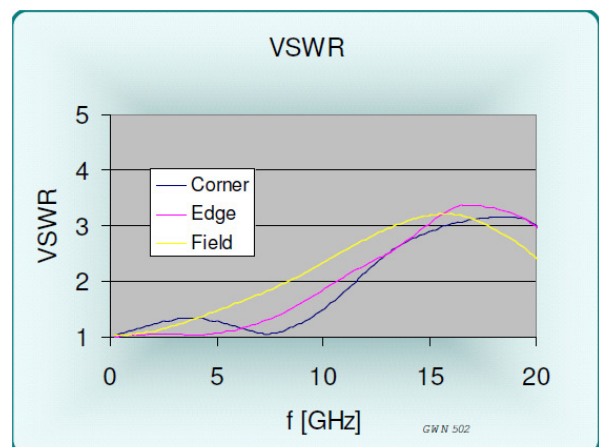

Figure 4: VSWR, D4697-B2

EQUIVALENT CIRCUITS / SPICE MODELS

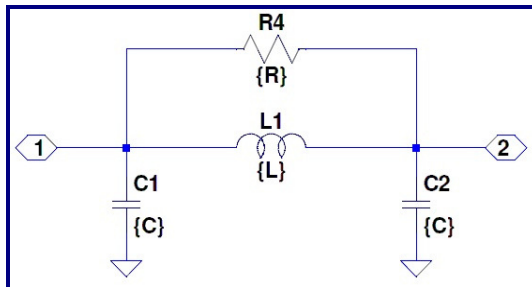

Figure 5: Pi Equivalent, Valid to >5 GHz

Site	Cg = C1+C2	L1	R4
Corner	0.736 pF	2.76 nH	800 Ω
Edge	0.861 pF	2.30 nH	600 Ω
Field	0.984 pF	2.01 nH	500 Ω
Diagonal	0.984 pF	2.01 nH	500 Ω

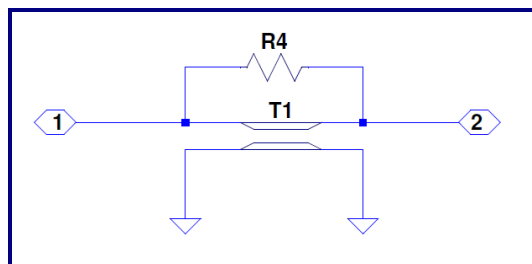

Figure 6: Transmission Line Model Valid <14.9 GHz

	Zo	L	R4
Corner	61.3 Ω	45.12 ps	1200 Ω
Edge	51.7 Ω	44.47 ps	900 Ω
Field	45.2 Ω	44.51 ps	800 Ω

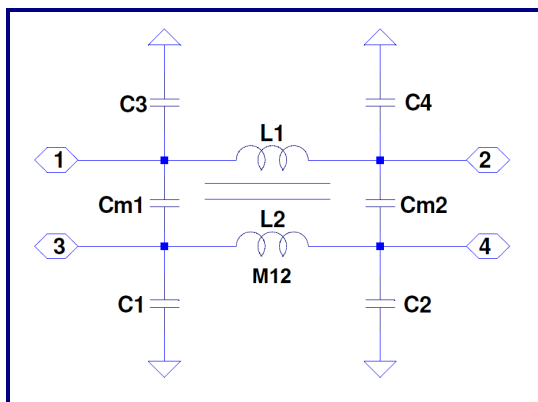

Figure 7: Lumped, Mutual Elements

Site	C1,2,3,4	Cm1,Cm2	L1,L2	M
Corner	0.230	0.138 pF	2.76	0.583 nH
Edge	0.330	0.101 pF	2.30	0.471 nH
Field	0.425	0.067 pF	2.01	0.304 nH
Diagonal	0.478	0.014 pF	2.01	0.098 nH

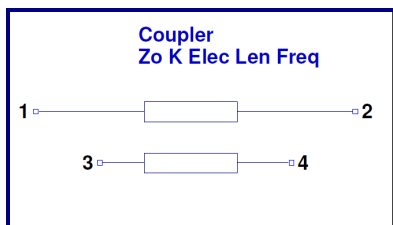
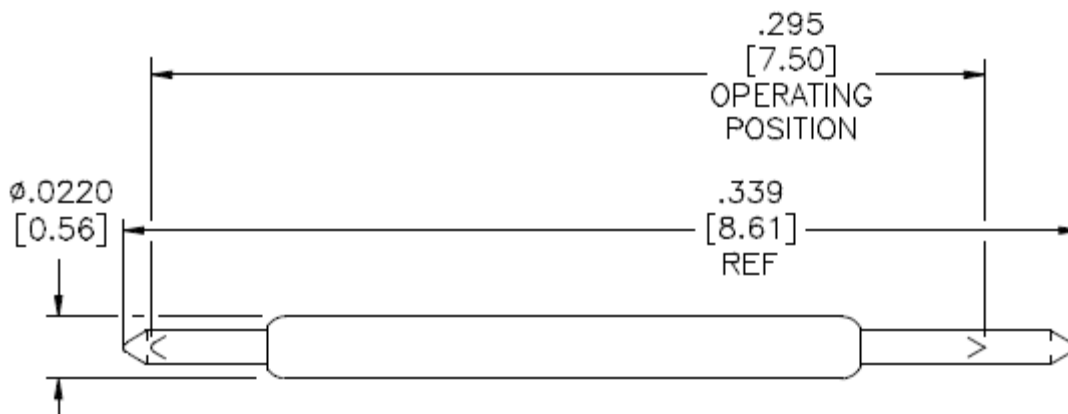

Figure 8: Transmission Line Equivalent for Crosstalk

Z0	39.3	Ohms
Lel	40.9	ps
k	0.15	
f	11.2	Ghz

D Series 0.8mm (.0315) pitch									
Probe Series	Initial Length		Operating Position		Spring Force	Self Inductance	Insertion Loss < -1db to	Typical Contact Resistance	Maximum Current
	inch/mm		inch/mm						
D4525	.087"	2.21	.071"	1.80	30 g	0.5 nH	17.0 GHz	20 mOhms	6.0 A
D4565	.092"	2.33	.071"	1.80	30 g	0.5 nH	17.0 GHz	25 mOhms	6.0 A
D4595	.154"	3.91	.128"	3.25	38 g	0.82 nH	19.5 GHz	30 mOhms	3.0 A
D4601	.214"	5.43	.186"	4.72	24-34 g	1.0 nH	12.8 GHz	50 mOhms	6.0 A
D4603	.209"	5.30	.181"	4.59	24 g	1.16 nH	12.4 GHz	70 mOhms	4.0 A
D4613	.249"	6.32	.213-.216"	5.49	24-34 g	1.25 nH	14.3 GHz	40 mOhms	2.15 A
D4623	.289"	7.33	.253"	6.43	34 g	1.55 nH	8.2 GHz	60 mOhms	5.4 A
D4823	.289"	7.33	.253"	6.43	28 g	-	-	-	-
D4693	.185"	4.71	.157"	4.00	24-34 g	0.92 nH	18.3 GHz	40 mOhms	3.0 A
D4694	.185"	4.71	.157"	4.00	23-36 g	0.80 nH	7.8 GHz	40 mOhms	3.0 A
D4697	.339"	8.61	.295"	7.50	32 g	2.01 nH	8.6 GHz	45 mOhms	2.6 A

MECHANICAL DIMENSIONS
INCHES [MM]



Signal Integrity, Inc.
104 County Street, Ste. 210, Attleboro, MA 02703
Tel: 1-508-226-6480 Fax: 1-508-226-6488 Internet: www.signalin.com

Signal Integrity makes no representation that the use of its products described herein, or the use of other technical information contained herein, will not infringe on existing or future patent rights. The descriptions contained herein do not imply the granting of licenses to make, use, or sell equipment constructed in accordance therewith. Specifications are subject to change without notice.