

FEATURES

- <-1db insertion loss to 13.9GHz
- <2:1VSWR to 12.35GHz
- 28-36g operating spring force
- $Z_0 = 36.9\Omega$
- 34.5ps risetime
- 20milliOhms contact resistance
- 6 Amps max. drive current

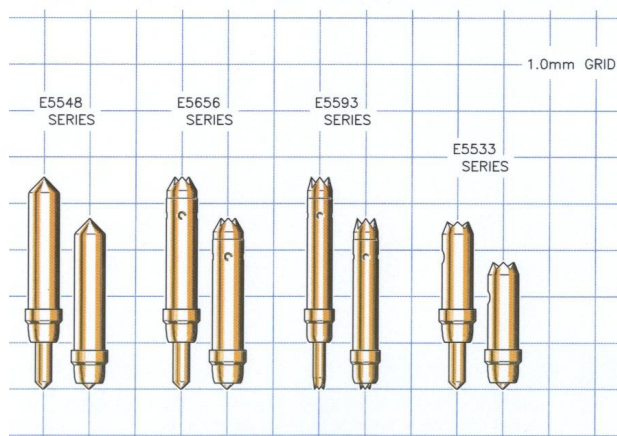

GENERAL DESCRIPTION

The E5656 spring probe from Signal Integrity Inc. is designed to meet the rigorous test requirements driven by the ultra fast risetimes in the digital domain, and high bandwidth, high frequency RF / microwave specifications for the wireless market. Along with speed and accuracy, these probes are designed to operate at pitches to 1.0mm, specifically for the fine pitch packaging these markets demand.

The very high bandwidth of these probes provides low insertion loss up to 13.9GHz. These probes will provide transparent operation on Bluetooth, 802.11b and 3G wireless protocol devices as well as exceed the test probe demands of proprietary microwave communications devices and systems.

With an impulse risetime of less than 34.5ps and a propagation delay of 24ps, the E5656 has more than enough performance for probe applications and interconnection solutions in broadband digital. These probes are ideal for building transparent test channels or interconnection solutions that must address data communication and source synchronous memory busses.

SERIES E5656 MODELS: ORDERING INFORMATION

E Series 1.0mm (.0394) Pitch				
Model	Length Operating / initial	DUT Plunger and Plating	Spring	Operating Spring Force
E5656-A1	.156 [3.96] / .180 [4.57] (inch [mm])	Crown - Gold	Stainless Steel	36 Grams
E5656-B2		Crown - Gold		36 Grams
E5656-C3		Reduced Crown - Gold		36 Grams
E5656-D4		Reduced Crown - Gold		36 Grams
E5656-E5		Reduced Crown - Gold		32 Grams
E5656-F6		Crown - Gold		32 Grams
E5656-G7		Crown - Gold (Spherical I'F)		32 Grams
E5656-H8		Red. Crown - Gold (Spherical I'F)		32 Grams
E5656-I9		Crown - Gold (Spherical I'F)		32 Grams
E5656-J1		Crown - Gold (Spherical I'F)		28 Grams

FUNCTIONAL SPECIFICATIONS

Model	E5656-D4			
Time Domain	Min.	Typ.	Max.	Units
TDT Risetime into 50Ω			34.5	ps
TDR Risetime open circuit			43.5	ps
TDR Risetime short circuit			39.0	ps
Signal Delay into 50Ω		24.0		ps
Frequency Domain				
Insertion Loss <-1db	13.9			GHz
<-3db	40.0			GHz
Return Loss, S11 <-10db	16.0			GHz
<-20db	3.0			GHz
VSWR <2:1	12.35			GHz
Equivalent Circuit Parameters				
Pin Inductance		0.90		nH
Pin Capacitance to ground		0.29		pF
Mutual Inductance		0.18		nH
Mutual Capacitance		0.05		pF
Transmission Line Zo		36.9		Ω
Tl		24.0		ps
DC Parameters				
Contact Resistance		20		mΩ
Maximum Rating				
Drive Current		6.0		A

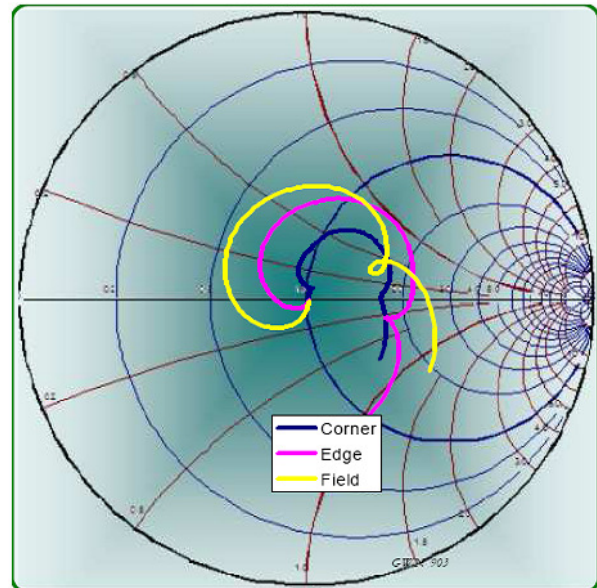

Figure 2: Measurement into 50Ω, E5656-B2

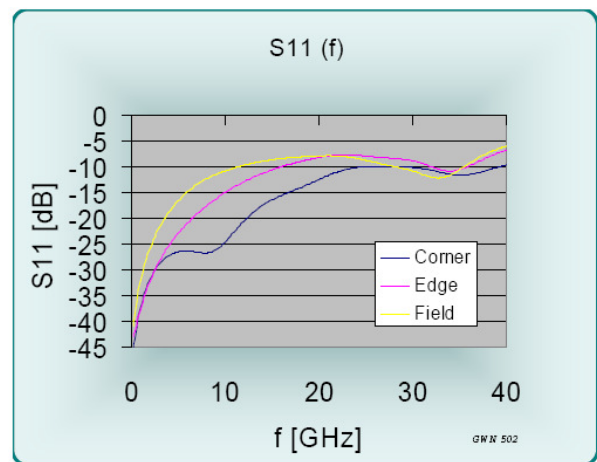

Figure 3: Return Loss, S11, E5656-B2

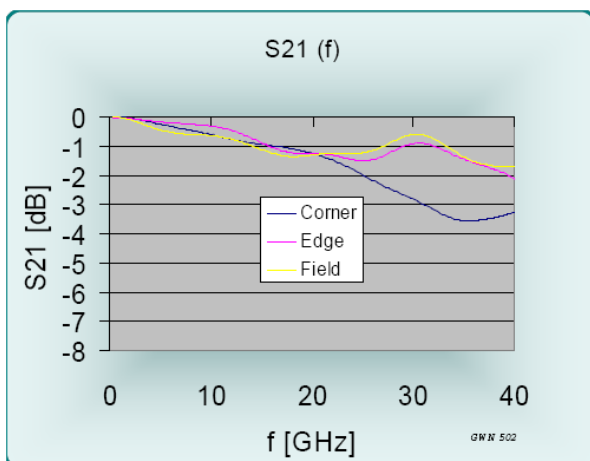

Figure 1: Insertion Loss, S21, E5656-B2

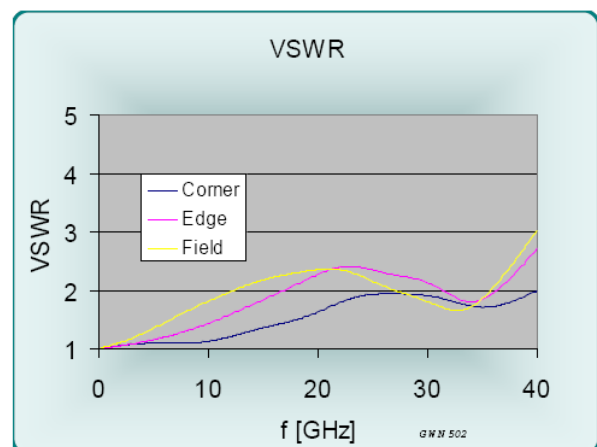

Figure 4: VSWR, E5656-B2

EQUIVALENT CIRCUITS / SPICE MODELS

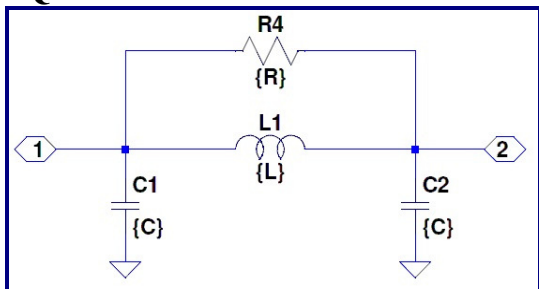

Figure 5: Pi Equivalent, Valid to <9GHz

C1, C2	0.290	pF
L1	1.90	nH

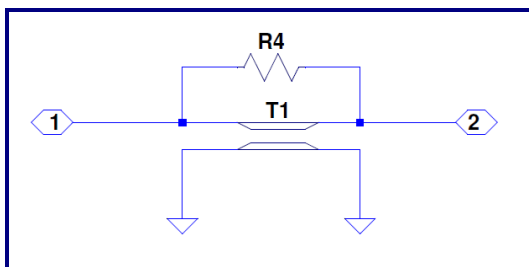

Figure 6: Transmission Line Model

Z0	36.9	Ohms
L	24	ps
R4	1,500	Ohms

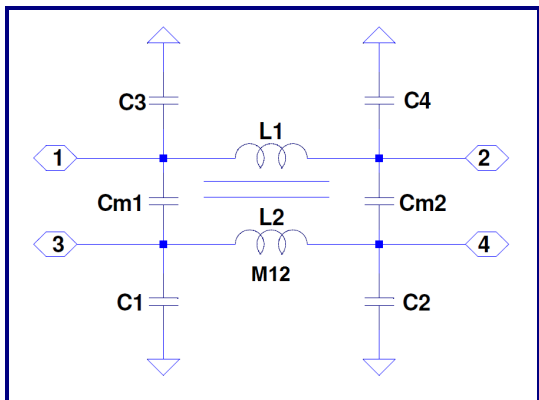

Figure 7: Lumped, Mutual Elements

C1,2,3,4	0.290	pF
Cm1, Cm2	0.05	pF
L1, L2	0.90	nH
M12	0.18	nH

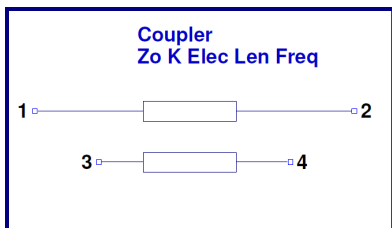

Figure 8: Transmission Line Equivalent for Crosstalk

Z0	36.9	Ohms
Tl	24	ps
K	0.11	
F	41.667	GHz

E SERIES MODELS

E Series 1.0mm (.0394) pitch									
Probe Series	Initial Length inch/mm		Operating Position inch/mm		Operating Spring Force	Self Inductance	Insertion Loss < -1db to	Typical Contact Resistance	Maximum Current
E5566	.121"	3.08	.098"	2.49	24-35 g	0.49 nH	>40 GHz	20 mOhms	4.3 A
E5533	.144"	3.66	.119"	3.02	25-40 g	0.72 nH	25.3 GHz	20 mOhms	8.5 A
E5548	.180"	4.57	.156"	3.96	20-39 g	1.04 nH	14.5 GHz	25 mOhms	7.0 A
E5593					27 g	1.14 nH	31.5 GHz	20 mOhms	6.0 A
E5656					28-36 g	0.90 nH	13.9 GHz	20 mOhms	6.0 A

v

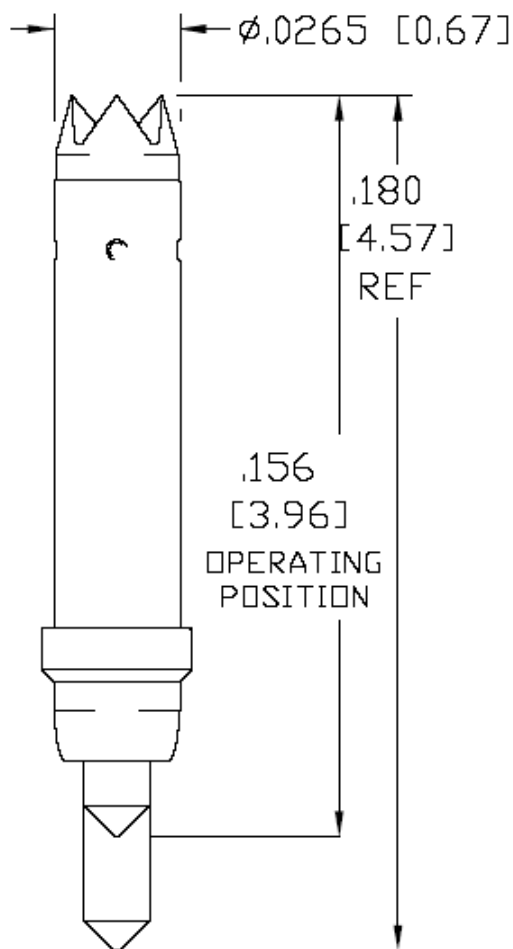
MECHANICAL DIMENSIONS
 INCHES [MM]

Signal Integrity, Inc.

104 County Street, Ste. 210, Attleboro, MA 02703

 Tel: 1-508-226-6480 Fax: 1-508-226-6488 Internet: www.signalin.com

Signal Integrity makes no representation that the use of its products described herein, or the use of other technical information contained herein, will not infringe on existing or future patent rights. The descriptions contained herein do not imply the granting of licenses to make, use, or sell equipment constructed in accordance therewith. Specifications are subject to change without notice.