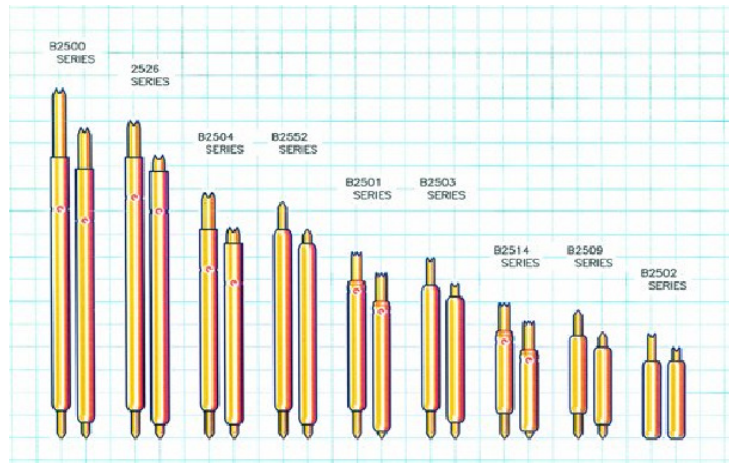

FEATURES

- <-1db insertion loss to 12.2GHz
- <2:1VSWR to 17.5GHz
- 26g operating spring force
- $Z_0 = 38.2\Omega$
- <33ps risetime
- 90mOhms contact resistance
- 2Amps max. drive current

GENERAL DESCRIPTION

The B2514 series spring probes from Signal Integrity Inc. are designed to meet the rigorous test requirements driven by the ultra fast risetimes in the digital domain, and high bandwidth, high frequency RF / microwave specifications for the wireless market. Along with speed and accuracy, these probes are designed to operate at pitches to 0.5mm, specifically for the ultra fine pitch packaging these markets demand.

The ultra high bandwidth of these probes provides very low insertion loss up to 12.2GHz. These probes will provide transparent operation on Bluetooth, 802.11b and 3G wireless protocol devices as well as exceed the test probe demands of proprietary microwave communications devices and systems.

With an impulse risetime of less than 33ps and a propagation delay of 15ps, the B2514 has more than enough performance for probe applications and interconnection solutions in broadband digital. These probes are ideal for building transparent test channels or interconnection solutions that must address datacom and source synchronous memory busses. Among others, these include Infiniband, PCI-Express, Source Synchronous DDR, Rambus[™], HyperTransport and 10Gb Ethernet.

SERIES B2514 MODELS: ORDERING INFORMATION

B Series 0.5mm (.0197inch) Pitch				
Model	Length Operating /Initial inches [mm]	DUT Plunger and Plating	Spring	Operating Spring Force
B2514-A1	.104 [2.64]/.116 [2.95]	Φ.0090 Crown - Gold	Music Wire	26 Grams
B2514-B2		Φ.0075 Conical - Gold	Music Wire	26 Grams
B2514-G7		Φ.0075 Crown - Gold	Music Wire	26 Grams

FUNCTIONAL SPECIFICATIONS

Model	B2514-A1			
Time Domain	Min.	Typ.	Max.	Units
TDT Risetime into 50Ω			33.0	ps
TDR Risetime open circuit			34.5	ps
TDR Risetime short circuit			33.0	ps
Signal Delay into 50Ω		15.0		ps
Frequency Domain				
Insertion Loss				
<-1.0db	12.2			GHz
<-2.0db	13.5			GHz
<-3.0db	21.9			GHz
Return loss				
<-10db	17.0			GHz
<-20db	5.0			GHz
VSWR				
<2:1	17.5			GHz
Equivalent Circuit Parameters				
Pin Inductance		0.63		nH
Pin Capacitance to ground		0.38		pF
Transmission Line Zo		38.2		Ohm
TI		15.0		ps
DC Parameters				
Contact Resistance		60		milliOhm
Maximum Rating				
Drive Current		2		A

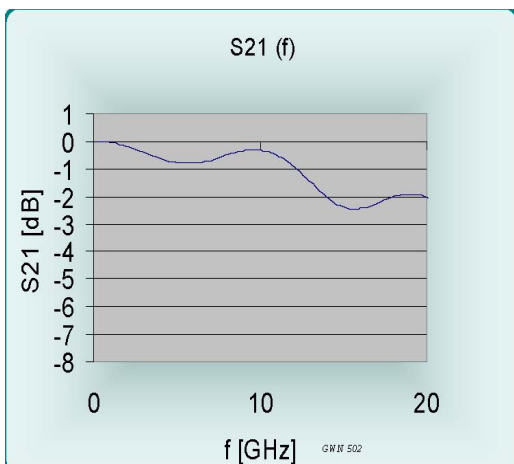
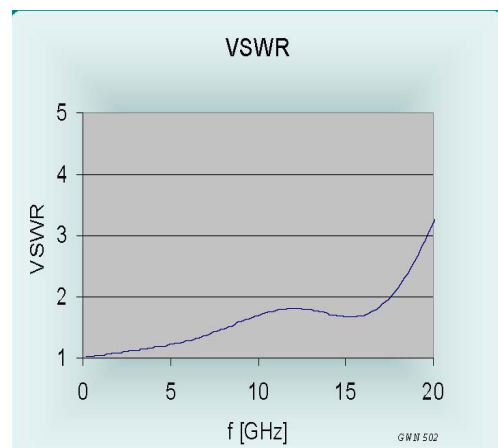

 Figure 1: Insertion Loss, S₂₁, B2514-A1

Figure 2: VSWR, B2514-A1

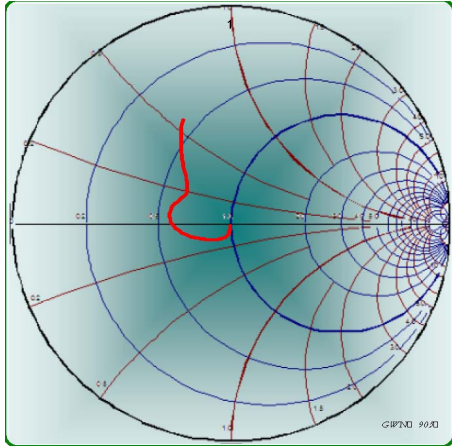

Figure 3: B2514-A1, Into 50Ω

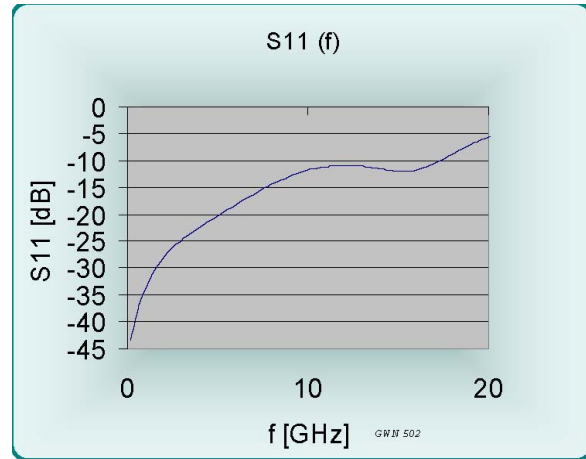

Figure 4: Return Loss, S11, B2514-A1

B SERIES MODELS

B Series 0.5mm (.0197 inch) Pitch

Probe Series	Initial Length inch / mm		Operating Position inch / mm		Spring Force	Self Inductance	Insertion Loss <-1db to	Typical Contact Resistance	Maximum Current
B2500	.304"	7.72	.275"	6.99	28 g	1.73 nH	6.4 GHz	80 mOhms	2.6 A
B2501	.162"	4.11	.150"	3.81	20-35 g	0.97 nH	11.2 GHz	50 mOhms	2.8 A
B2502	.091"	2.31	.085"	2.16	32 g	0.54 nH	17.0 GHz	30 mOhms	1.5 A
B2503	.157"	3.99	.142"	3.61	26-32 g	0.71 nH	13.0 GHz	60 mOhms	1.7 A
B2504	.214"	5.42	.190"	4.82	24-34 g	1.12 nH	8.8 GHz	60 mOhms	2.9 A
B2509	.108"	2.74	.094"	2.39	26 g	0.60 nH	13.2 GHz	90 mOhms	2.0 A
B2514	.116"	2.95	.104"	2.64	26 g	0.63 nH	12.2 GHz	90 mOhms	2.0 A
B2535	.217"	5.50	.199"	5.05	26-31 g	~	~	55 mOhms	2.3 A

MECHANICAL DIMENSIONS
INCHES [MM]

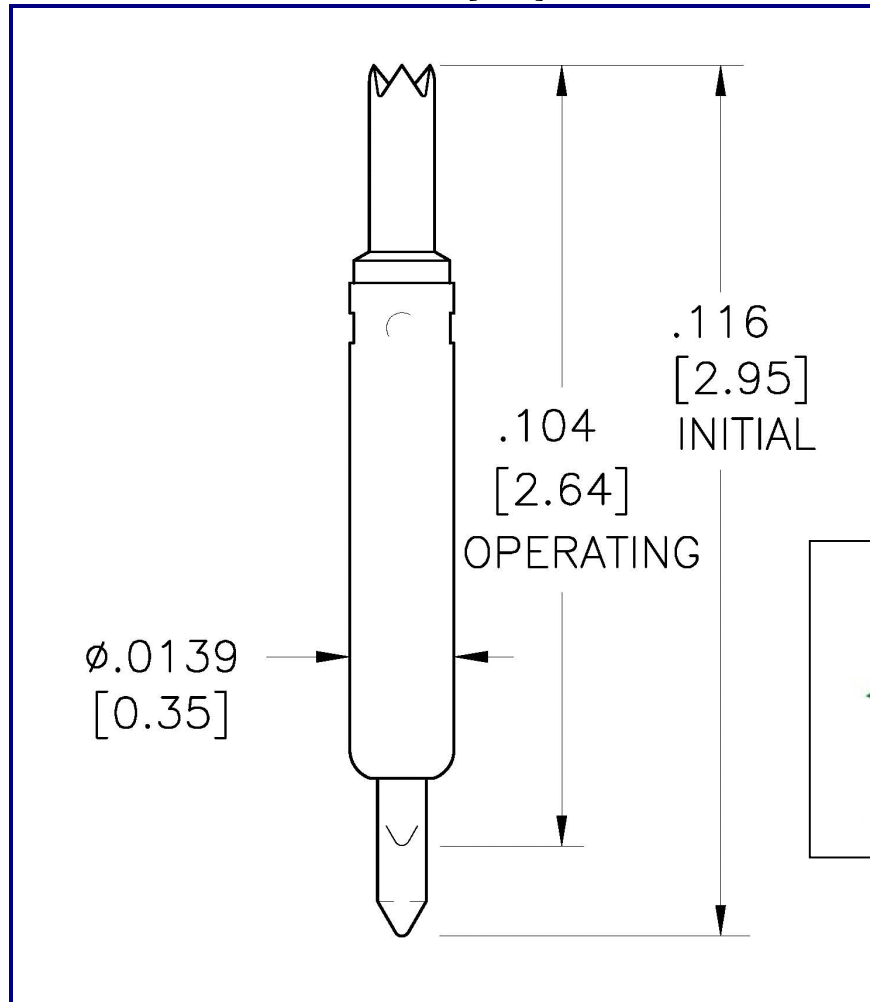

Signal Integrity, Inc.
104 County Street, Suite 210, Attleboro, MA 02703
Tel: 1-508-226-6480 Email: sales@signalin.com Internet: www.signalin.com

Signal Integrity makes no representation that the use of its products described herein, or the use of other technical information contained herein, will not infringe on existing or future patent rights. The descriptions contained herein do not imply the granting of licenses to make, use, or sell equipment constructed in accordance therewith. Specifications are subject to change without notice.