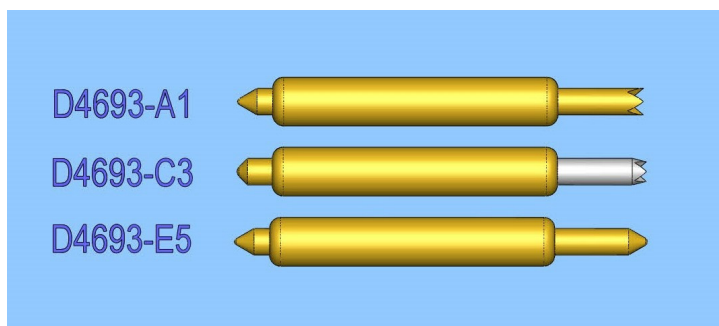

FEATURES

- <-1db insertion loss to 18.3 GHz
- <2:1VSWR to 12.0 GHz
- 34g operating spring force
- $Z_0 = 34.6\Omega$
- <33.0 ps risetime
- 40 milliOhms contact resistance
- 3 Amp max. drive current

GENERAL DESCRIPTION

The D4693 series spring probes from Signal Integrity Inc. are designed to meet the rigorous test probe bandwidth of the wireless and RF test markets as well as very fast rise times in test applications for telecommunication and broadband data communications system-on-a-chip devices. The risetime requirements for these devices are usually well below 150 picoseconds. Along with speed and accuracy, these probes are designed for testing very fine pitch to 0.8mm, well suited to the packaging constraints driven by the consumer wireless market.

The high bandwidth of these probes provides very low insertion loss up to 18.3GHz. These probes will provide transparent operation on Bluetooth, 802.11b and 3G wireless protocol devices as well as exceed the test probe demands of proprietary microwave communications devices and systems.

With an impulse risetime of less than 33.0ps and a propagation delay of 25.2ps, the AC performance of the D4693 probe is transparent for test applications and interconnections solutions that operate in high speed CMOS, SiGe and GaAs technologies.

D4693 ORDERING INFORMATION

D Series 0.8mm (.0315) Pitch					
Model	Length Operating/Initial inch [mm]	DUT Plunger - Plating	Interface Plunger	Operating Spring Force	
D4693-A1	.157 [4.00] / .185 [4.71]	Crown - Gold	Conic - Gold	24 Grams	
D4693-B2		Crown - Palladium	Radius - Gold	34 Grams	
D4693-C3		Reduced Crown - Pd			
D4693-D4		Crown - Gold	Conic - Gold	24 Grams	
D4693-E5		Conic - Gold			
D4693-F6		Reduced Crown - Pd	Radius - Gold	38 Grams	
D4693-G7		Reduced Crown - Gold	Conic - Gold		
D4693-H8		Crown - Palladium			
D4693-J9		Reduced Crown - Gold			
D4693-K2		Anti-Diffusion	Radius - Gold		
D4693-L3		Crown - Solid Pd Alloy	Conic - Gold	34 Grams	
D4693-M4		Conic - Gold			
D4693-N5		Crown - Solid Pd Alloy		24 Grams	
D4693-P6		Crown - Gold	Radius - Gold	34 Grams	
			Anti-Diffusion		

FUNCTIONAL SPECIFICATIONS

Model	D4693-A1			
Time Domain	Min.	Typ.	Max.	Units
TDT Risetime into 50Ω			33.0	ps
TDR Risetime open circuit			52.5	ps
TDR Risetime short circuit			49.5	ps
Signal Delay into 50Ω		25.2		ps
Frequency Domain				
Insertion Loss <-1db	17.7			GHz
<-3db	40.05			GHz
Return Loss, S11 <-10db	7.6			GHz
<-20db	2.4			GHz
VSWR <2:1	28.69			GHz
Equivalent Circuit Parameters				
Pin Inductance		0.92		nH
Pin Capacitance to ground		0.60		pF
Mutual Inductance		0.196		nH
Mutual Capacitance		0.098		pF
Transmission Line Zo		34.6		Ω
Tl		23.4		ps
DC Parameters				
Contact Resistance		40		mΩ
Maximum Rating				
Drive Current		3.0		A

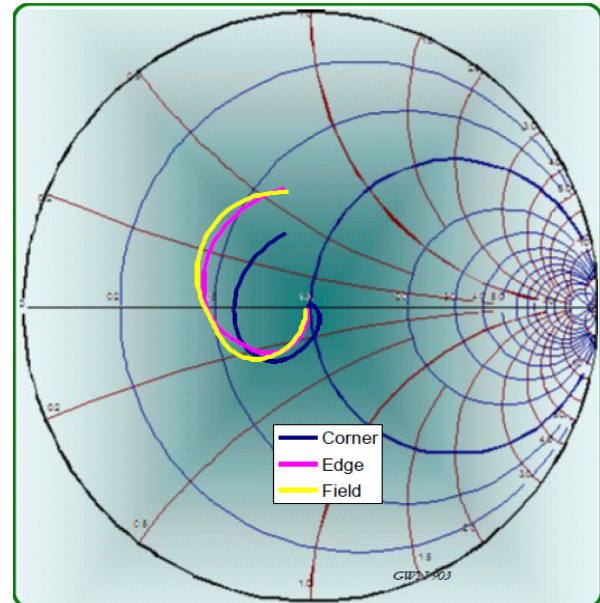

Figure 2: Measurement into 50Ω, D4693-A1

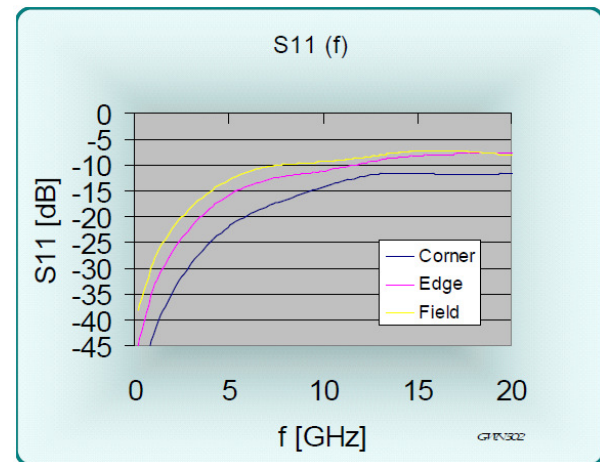

Figure 3: Return Loss, S11, D4693-A1

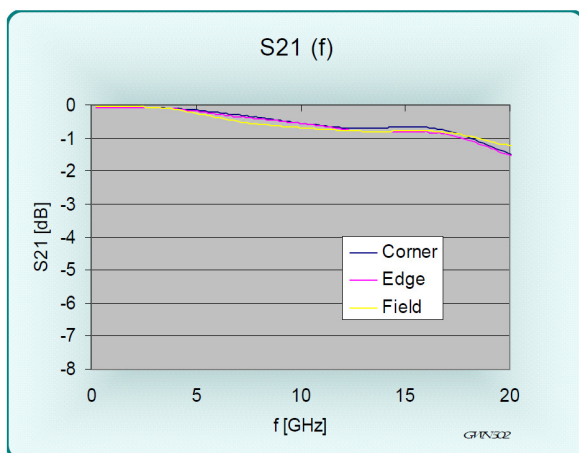

Figure 1: Insertion Loss, S21, D4693-A1

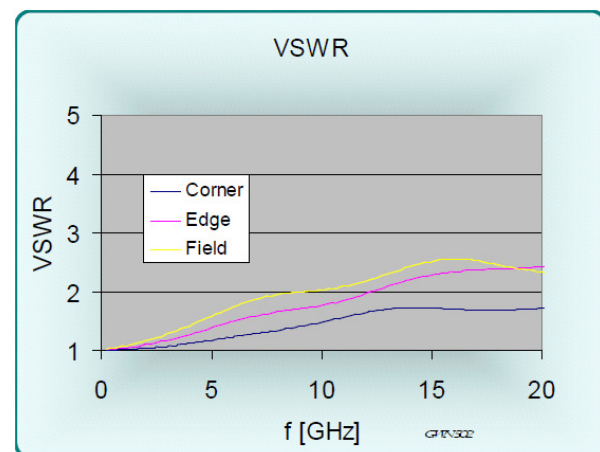

Figure 4: VSWR, D4693-A1

EQUIVALENT CIRCUITS / SPICE MODELS

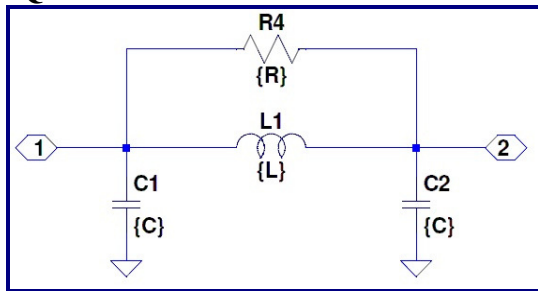

Figure 5: Pi Equivalent, Valid to <9 GHz

Site	Cg = C1+C2	L1	R4
Corner	0.474 pF	1.35 nH	1000 Ω
Edge	0.563 pF	1.08 nH	1000 Ω
Field	0.600 pF	0.92 nH	1000 Ω
Diagonal	0.600 pF	0.92 nH	1000 Ω

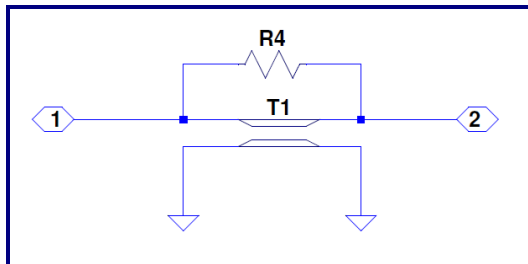

Figure 6: Transmission Line Model Valid to >40GHz

	Zo	L	R4
Corner	53.4 Ω	25.29 ps	1000 Ω
Edge	43.7 Ω	24.62 ps	1000 Ω
Field	39.1 Ω	23.48 ps	1000 Ω

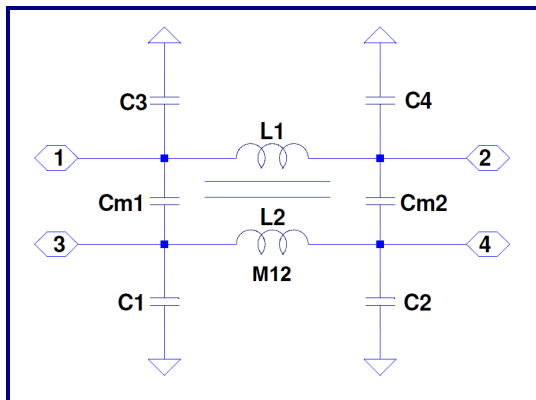

Figure 7: Lumped, Mutual Elements

Site	C1,2,3,4	Cm1,Cm2	L1,L2	M
Corner	0.237	0.087 pF	1.35	0.408 nH
Edge	0.281	0.073 pF	1.08	0.316 nH
Field	0.300	0.049 pF	0.92	0.196 nH
Diagonal	0.300	0.008 pF	0.92	0.036 nH

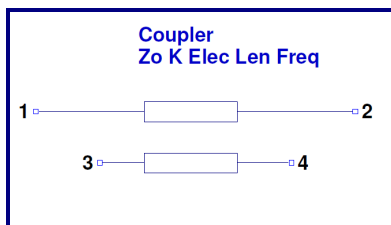
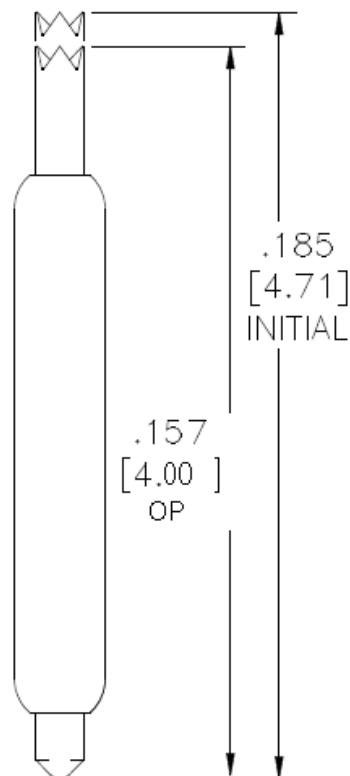

Figure 8: Transmission Line Equivalent for Crosstalk

Z0	34.6	Ohms
Lel	23.4	ps
k	0.21	
f	19.6	Ghz

D Series 0.8mm (.0315) pitch									
Probe Series	Initial Length		Operating Position		Spring Force	Self Inductance	Insertion Loss < -1db to	Typical Contact Resistance	Maximum Current
	inch/mm	inch/mm	inch/mm	inch/mm					
D4525	.087"	2.21	.071"	1.80	30 g	0.5 nH	17.0 GHz	20 mOhms	6.0 A
D4565	.092"	2.33	.071"	1.80	30 g	0.5 nH	17.0 GHz	25 mOhms	6.0 A
D4595	.154"	3.91	.128"	3.25	38 g	0.82 nH	19.5 GHz	30 mOhms	3.0 A
D4601	.214"	5.43	.186"	4.72	24-34 g	1.0 nH	12.8 GHz	50 mOhms	6.0 A
D4603	.209"	5.30	.181"	4.59	24 g	1.16 nH	12.4 GHz	70 mOhms	4.0 A
D4613	.249"	6.32	.213-.216"	5.49	24-34 g	1.25 nH	14.3 GHz	40 mOhms	2.15 A
D4623	.289"	7.33	.253"	6.43	34 g	1.55 nH	8.2 GHz	60 mOhms	5.4 A
D4823	.289"	7.33	.253"	6.43	28 g	-	-	-	-
D4693	.185"	4.71	.157"	4.00	24-34 g	0.92 nH	18.3 GHz	40 mOhms	3.0 A
D4694	.185"	4.71	.157"	4.00	23-36 g	0.80 nH	7.8 GHz	40 mOhms	3.0 A
D4697	.339"	8.61	.295"	7.50	32 g	2.01 nH	8.6 GHz	45 mOhms	2.6 A

MECHANICAL DIMENSIONS INCHES [MM]

Signal Integrity, Inc.

104 County Street, Ste. 210, Attleboro, MA 02703

Tel: 1-508-226-6480 Email: sales@signalin.com Internet: www.signalin.com

Signal Integrity makes no representation that the use of its products described herein, or the use of other technical information contained herein, will not infringe on existing or future patent rights. The descriptions contained herein do not imply the granting of licenses to make, use, or sell equipment constructed in accordance therewith. Specifications are subject to change without notice.